

A Brief History of Musical Synthesis

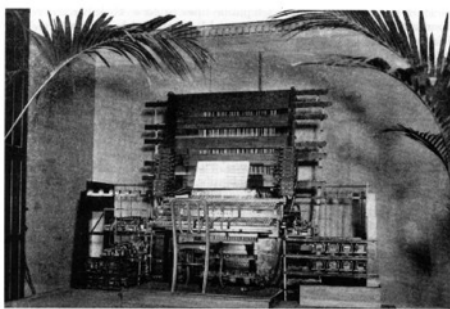

Pat Scandalis
CTO moForte Inc

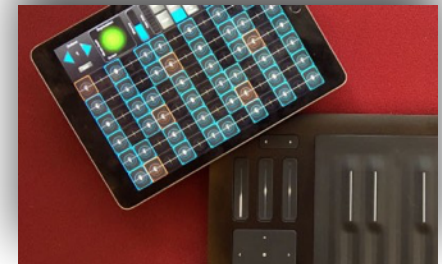
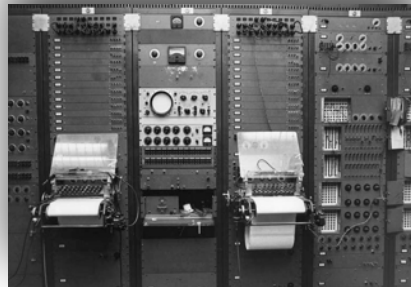
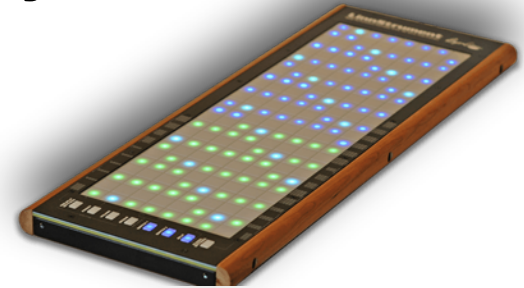

Jordan Rudess KeyFest 2016

The Seminar Presentation

<http://www.moforte.com/keyfest2016/>

Overview



- **Synthesis in the Age of Radio. Tubes!**
- **Synthesis Techniques**
- **Modern Synth Instruments**
- **The Future**

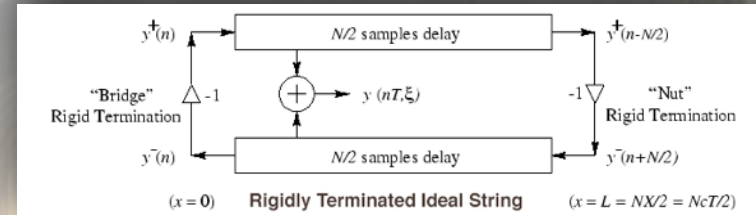

About Pat...

- 33 years in the Silicon Valley as an Engineer
- Built my first monophonic electronic instrument in 1970 from a Radio Shack kit.
- Gigged with an Arp Avatar guitar synth (1978)
- Computer Modeling of strings and membranes (1981)
- Researcher in Physical Modeling at Stanford/CCRMA (1994)
- CTO of moForte

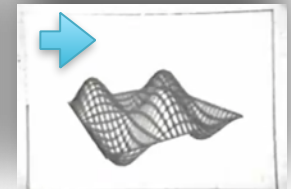

What is your First Impression of a Synthesizer?

- People have always searched for new expressive ways to perform music and sound, ways to explore new timbres.
- I believe that many people who are interested in synthesized sound, experience music with Synesthesia
- My first impression was “Switched On Bach” - Wendy Carlos 1968

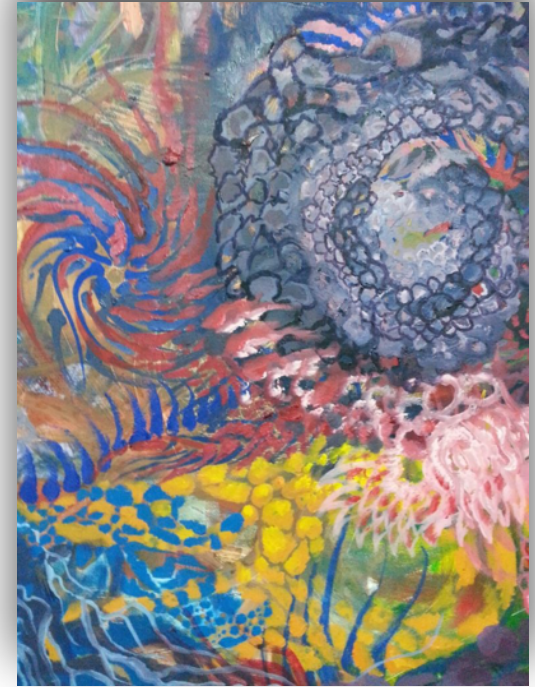

[Jessica Seeley](#)



Trick Question: What was the first subscription music service?



Subscription services

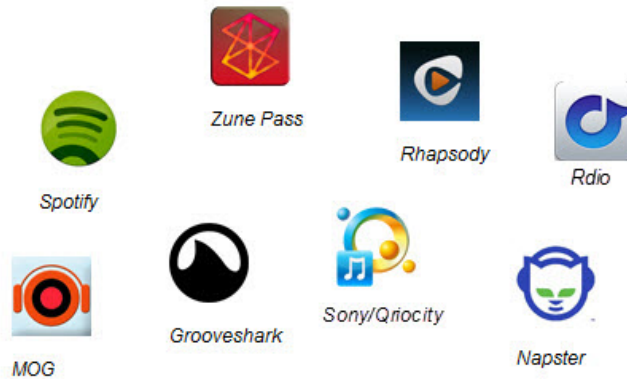

Music lockers



The Telharmonium Mark II

Thaddeus Cahill (1897 - 1912)

- Tone Wheel additive synthesis like a Hammond Organ
- ... Except that it weighted 200 tons.
- Looks like a steam punk data center
- Telharmonium tones where sine waves. “Clear and pure”.
- Subscription model. Broadcast to businesses and telephones.
- Funded like a modern venture (\$200k = \$5M), pitching, patents, road show ...
- Cross talk with phone lines was a problem
- No recordings. Last parts scrapped in 1962

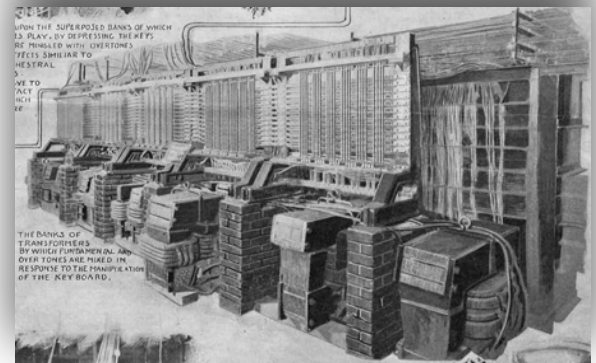
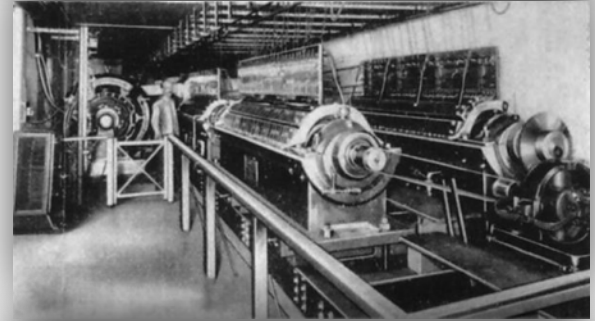
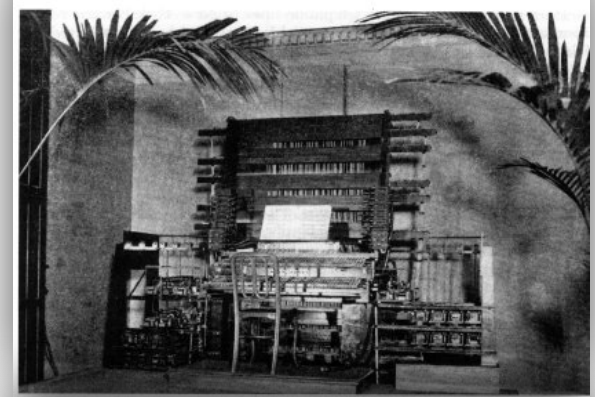

Early Electronic/Electro Mechanical Instruments from the Age of Radio

- Telharmonium (1897)
- Player Pianos (1900)
- Theremin (1920)
- Ondes Martenot (1928)
- Trautonium (1929)
- Hammond Organ (1935)
- The Ondioline (1941)
- Novachord (1939)
- The Voder



Player Pianos (1900 - Present)

- Some designs as early as 1876
- Pianola and reproducing pianos.
- Peaked in 1924,
- Audio recordings are still made from reproducing rolls (Stravinsky, “Rite of Spring”)
- [QRS Documentary “Punching a Hole ... Playing a Roll”](#).
- Modern realizations include the Disklavier, QRS PNOmation ..



Theremin (1920)

- As a young physicist Theremin did Soviet sponsored research on proximity sensors.
- Came to the US and patented the Theremin in 1928. Licensed to RCA
- Audio is generated via heterodyning (@500k). The frequency antenna is used to set the f of a pitch oscillator that “beats” against a reference oscillator.
- Clara Rockmore became an acclaimed classical player. Lydia Kavina as well.
- Robert Moog built Theremins in college.
- Used for [“The Day the Earth Stood Still”](#).
- The Theremin remains a popular and relevant instrument.

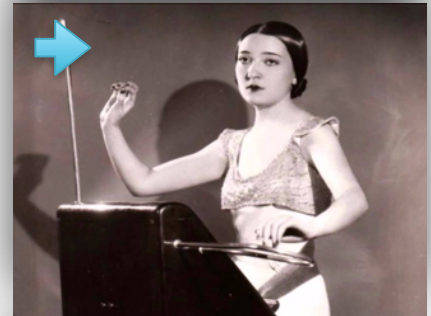
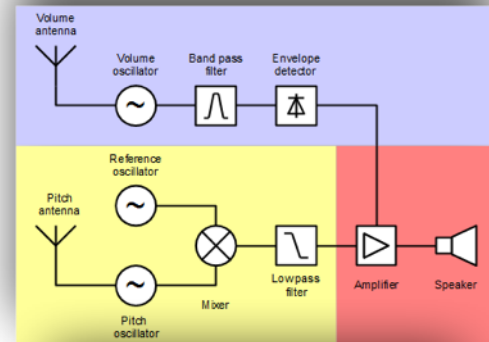
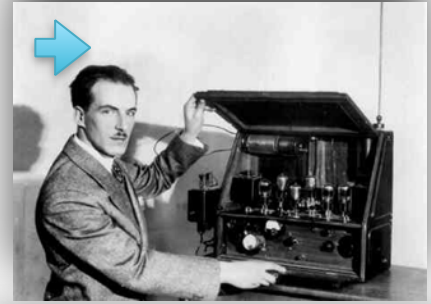

Theremin KGB Footnote (1945-1952)

- [Documentary “Theremin and Electronic Odyssey”](#)
- Kidnapped by KGB and returned to the Soviet Union in 1938.
- Created “The Thing”, an ingenious passive listening bug in the US ambassador’s office for 7 years.
- Disguised as the Great Seal of the United States, gifted to the ambassador by the Young Pioneers.
- Theremin returned to the US in 1991 and visited Stanford/CCRMA.

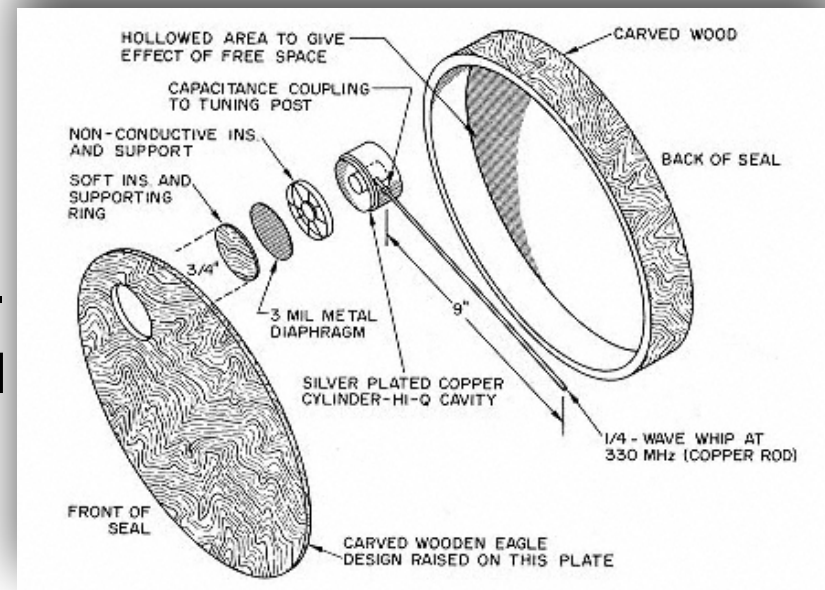

Ondes Martenot (1928)

- Similar principle as the Theremin
- Traditional keyboard, sliding pitch ring (like the Roli Rise), and force sensitive dynamics bar (touche d'intensité).
- Switches select various waveforms, sine, triangle, square, pulse train, and pink noise!
- Different types of speakers are used as resonators.
- Used in classical repertoire and film scores.
- Was manufactured as late as 1988.



Trautonium (1929)

- No keyboard. Resistive wires that contact a conductive plate. The user can be slide back and forth on the wire. In some ways similar to the continuum.
- Relaxation Oscillators (tube) that produce triangle and square waves.
- Envelopes, noise, formant filters. Its a subtractive synth!
- Used in Hitchcock's ["The Birds"](#)
- Development continued until 2002

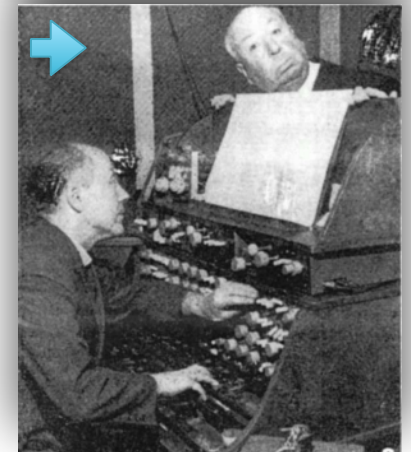

Hammond Organ (1935)

- Mechanical tone wheel additive synthesis.
- Like the Telharmonium, except instead of 200 tons it only weights 400 lbs ;-)
- Based on synchronous clock motor
- Manuals, drawbars, presets, vibrato, chorus, harmonic percussion with legato, Leslie Speakers, bass pedals. Its a Beast!
- While playing, you could turn off the motor and it would sound like the end of the world!



The Voder (1937-39) - Homer Dudley

- Analog Electronic Speech Synthesis
- Analog model of the vocal tract
- Develop from research on voice compression at Bell Labs.
- Featured at the 1939 Worlds fair
- [YouTube](#)

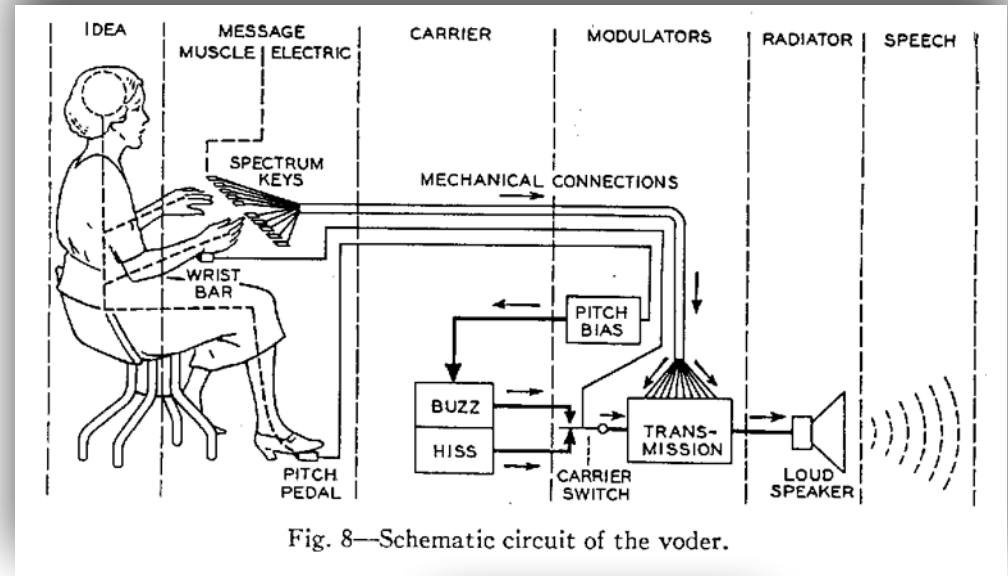

Novachord (1939)

- First polyphonic subtractive synth!
- ADSR with 7 preset envelopes
- Resonant filters
- 163 tubes, 1000 caps
- The Polymoog uses a similar polyphonic design
- #1 went to FDR
- Only 1069 ever made only 200 extant. Few still operate.

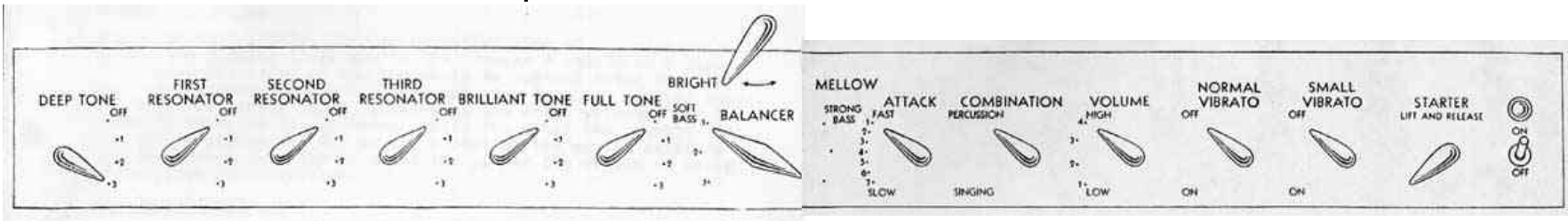

The Ondioline (1941)

- Forerunner of today's synths.
- Still uses tubes, but not the Theremin circuit. Its a multivibrator oscillator with rich harmonics + a complex filter bank. Subtractive synthesis!
- The Keyboard was mounted on springs so that it could be wiggled for vibrato.
- Used extensively on Motown recordings in place of union string players.
- 900 build, only about 12 still exist.



Optical Synthesis (1937-1957)

- Waveforms on optical media performed using photoelectric circuits.
- Phototone Organ - Edwin Welte (1937)
- ANS Synthesizer - Yevgeny Murzin (1937-1957). Named for Alexander Nikolayevich Scriabin. Used in the soundtrack for Solaris.
- Oramics - Daphne Oram BBC Radio Workshop (1957)

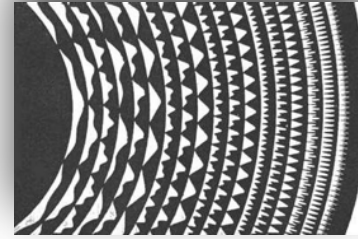

Early Sequencing

- Pin Barrels (1400ss)
- Music Boxes (1800s)
- Player Pianos (1900s)
- The RCA Mark II (Victor) did sequencing with a piano roll like interface (1957). Mix down was engraved to a lacquer record.
- Buchla 100 (1964)

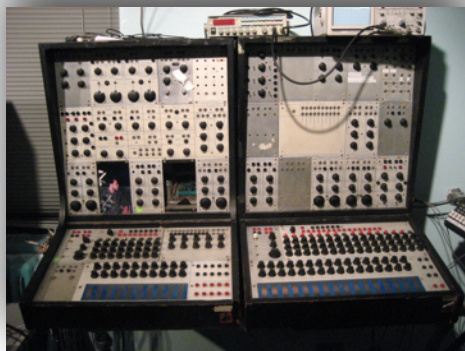
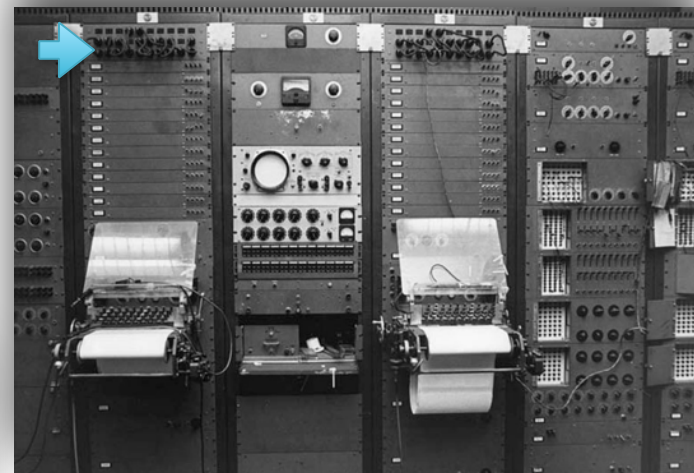
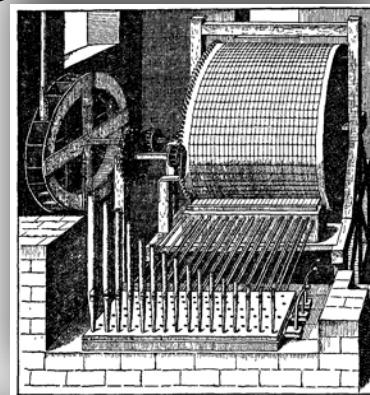

Synthesis Techniques

- Additive
- Subtractive
- Sampling
- Physical Modeling
- KS
- WaveGuide
- Modal
- Analog Modeling
- Formant Synthesis
- FM and Phase Distortion
- Granular Synthesis
- WaveTable
- Spectral Morphing
- Linear Arithmetic
- Vector Synthesis
- Circuit Bending
- Vocoding

Voltage Control (1940s)

- Invented by Hugh Le Caine for the Electronic Sackbut.
- Supported control of volume, pitch and timbre with voltage control
- Buchla and Moog adopted. Standard for control through the 60s and 70s.



Additive (1897)

- Adding Sine waves
- Telharmonium (1897)
- Hammond Organs (1937)
- Fairlight CMI (1976)
- Bell Labs Digital Synthesizer, [Alice](#) (1977)
- Synclavier II (1979)
- As evolved to additive analysis/resynthesis (SMS)



Subtractive (1939)

- Harmonically rich waveforms + filters
 - Filters typically Low Pass, Band Pass, Notch Pass, High Pass
 - Envelopes to control filters
- Hammond Novachord (1939)
- Moog ([Moog Documentary](#)) (1964)
- Buchla 100 series (1960s)
- Arp Odyssey (1972)
- Korg MS-20 and others (1978)

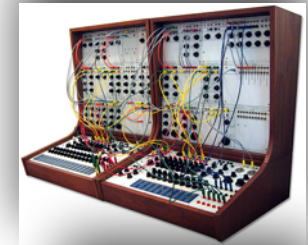

Sampling (1949)

- Sampled Recordings
- Chamberlin (1949)
- Mellotron ([Documentary](#)) (1963)
- EMS Musys system (1969)
- Mattel Opticon (1970)
- Fairlight CMI (1979)
- Emulator (1981)



Physical Modeling (1983)

- Karplus-Strong (KS)
- Extended Karplus-Strong (EKS)
- Digital Waveguide
- Commuted Synthesis
- Coupled Mode Synthesis (CMS)
- Virtual Analog (VA)

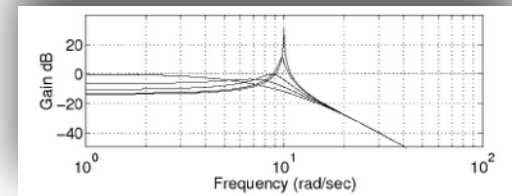
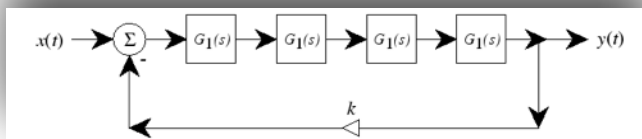
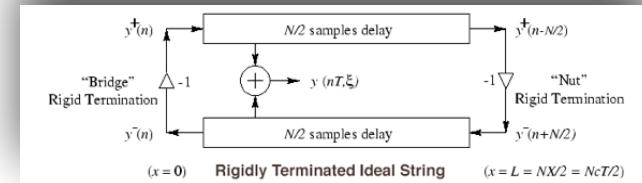
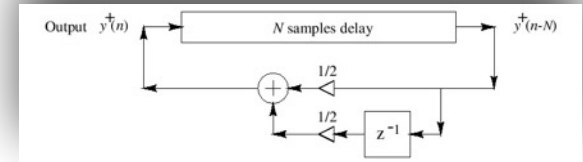

Karplus-Strong (KS) Algorithm (1983)

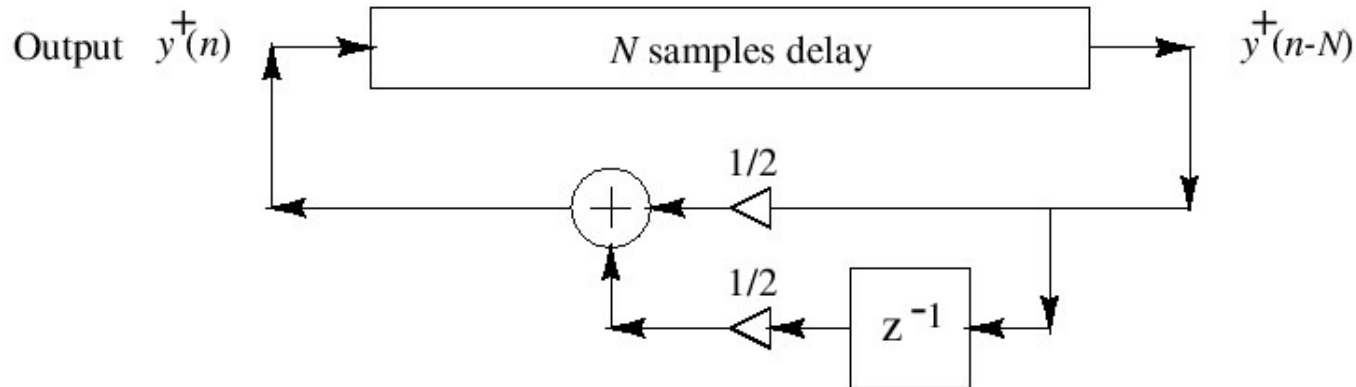

- Discovered (1978) as “self-modifying wavetable synthesis”
- Wavetable is preferably initialized with random numbers
- Licensed to Mattel
- The first musical use of the algorithm was in the work “*May All Your Children Be Acrobats*” written in 1981 by David A. Jaffe.
[\(MP3\)](#)

EKS Algorithm (Jaffe-Smith 1983)

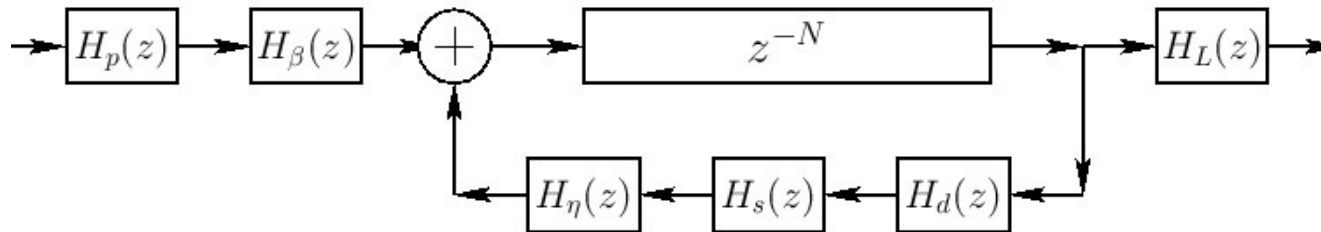

$$H_p(z) = \frac{1-p}{1-pz^{-1}} = \text{pick-direction lowpass filter}$$

$$H_\beta(z) = 1 - z^{-\lfloor \beta N + 1/2 \rfloor} = \text{pick-position comb filter, } \beta \in (0, 1)$$

$$H_d(z) = \text{string-damping filter (one/two poles/zeros typical)}$$

$$H_s(z) = \text{string-stiffness allpass filter (several poles and zeros)}$$

$$H_\eta(z) = -\frac{\eta(N) - z^{-1}}{1 - \eta(N)z^{-1}} = \text{first-order string-tuning allpass filter}$$

$$H_L(z) = \frac{1-R_L}{1-R_Lz^{-1}} = \text{dynamic-level lowpass filter}$$

- Musical Example “Silicon Valley Breakdown” (Jaffe 1992) [\(MP3\)](#)
- Musical Example BWV-1041 (used to intro the NeXT machine 1988) [\(MP3\)](#)

Digital Waveguide Models (Smith 1985)

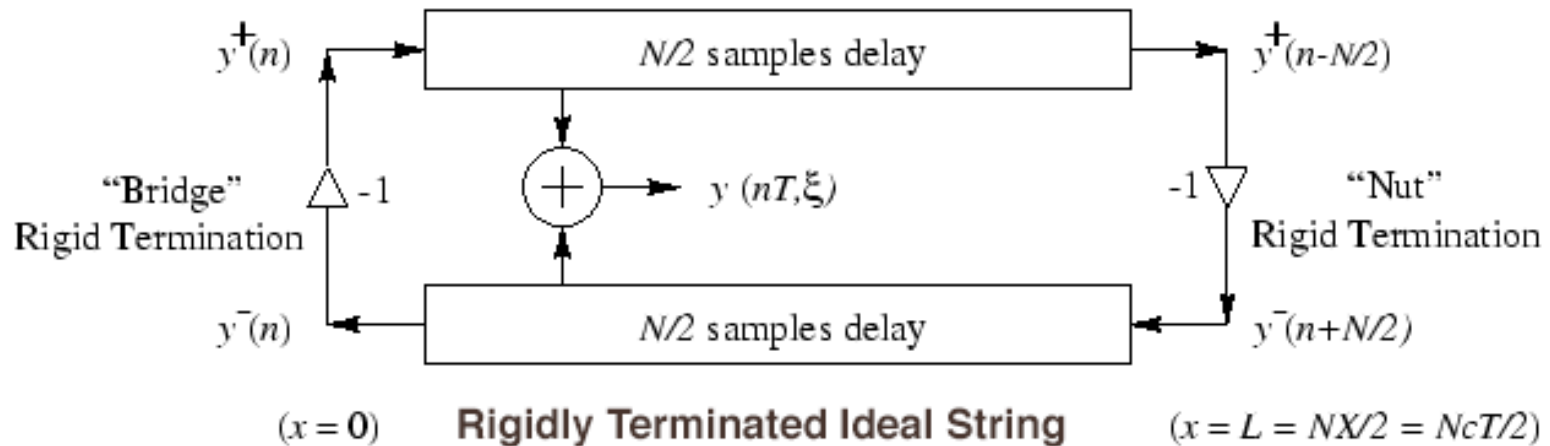

- Equivalent to d'Alembert's Solution to the Partial Differential Equation for a string (1747)
- Useful for efficient models of
 - Strings
 - Bores
 - plane waves
 - conical waves

Commutated Synthesis (Smith) (1994)



Schematic diagram of a stringed musical instrument.



Equivalent diagram in the linear, time-invariant case.

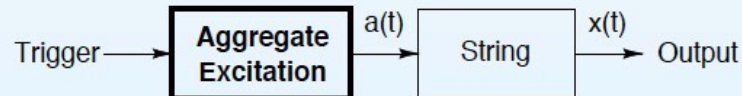

Use of an aggregate excitation given by the convolution of original excitation with the resonator impulse response.

Commutated Synthesis Examples

- Electric guitar, different pickups and bodies (Sondius) [\(MP3\)](#)
- Mandolin (STK) [\(MP3\)](#)
- Classical Guitar (Mikael Laurson, Cumhur Erkut, and Vesa Välimäki) [\(MP3\)](#)
- Bass (Sondius) [\(MP3\)](#)
- Upright Bass (Sondius) [\(MP3\)](#)
- Cello (Sondius) [\(MP3\)](#)
- Piano (Sondius) [\(MP3\)](#)
- Harpsichord (Sondius) [\(MP3\)](#)

Coupled Mode Synthesis (CMS) (Van Duyne) (1996)

- Modeling of percussion sounds
- Modal technique with coupling
- Tibetan Bell Model ([MP3](#))
- Wind Chime Model ([MP3](#))
- Tubular Bells Model ([MP3](#))
- Percussion Ensemble ([MP3](#))

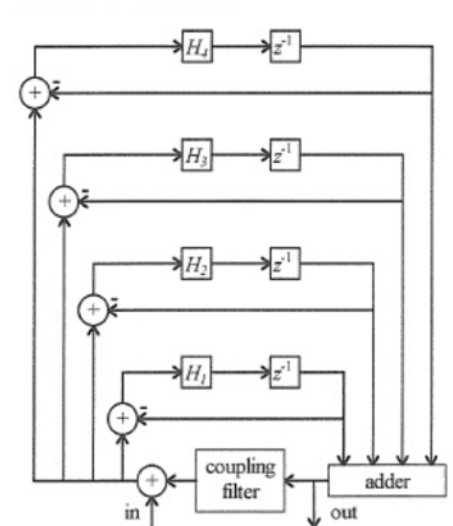
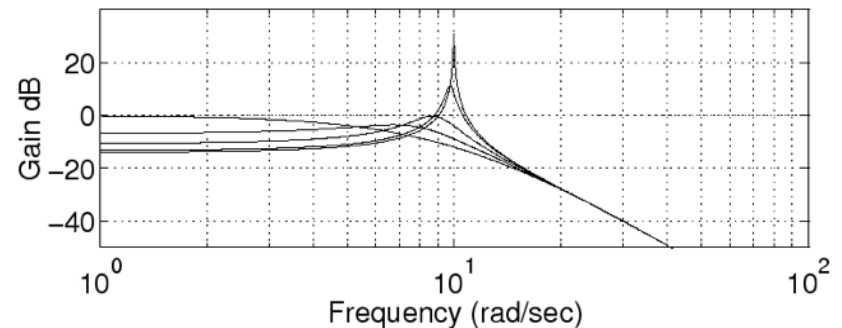
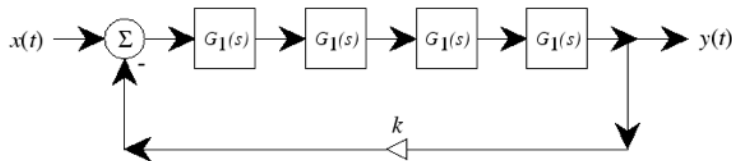

Figure 2: The Coupled Mode Filter Structure

Virtual Analog (Stilson-Smith) (1996)

- Alias-Free Digital Synthesis of Classic Analog Waveforms
- Digital implementation of the Moog VCF. Four identical one-poles in series with a feedback loop.
- Sounds great! [\(MP3\)](#) [\(youTube\)](#)



Yamaha VL Line (1994)

- Yamaha Licensed “Digital Waveguide Synthesis” for use in its products including the VL line (VL-1, VL-1m, VL-70m, EX-5, EX-7, chip sets, sound cards, soft-synth drivers)
- Shakuhachi: [\(MP3\)](#)
- Oboe and Bassoon: [\(MP3\)](#)
- Tenor Saxophone: [\(MP3\)](#)



Korg SynthKit Line (1994)

- SynthKit (1994)
- Prophecy (1995)
- Trinity (1995)
- OASYS PCI (1999)
- OASYS (2005)
- Kronos (2011)

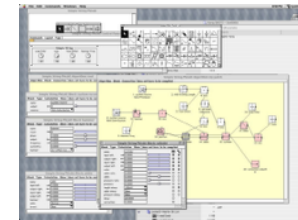
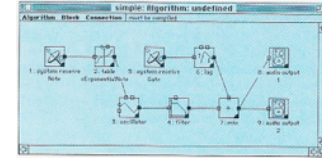

Seer Systems “Reality” (1997)



- Stanley Jungleib, Dave Smith (MIDI, Sequential Circuits)
- Ring-0 SW MIDI synth. Native Signal Processing.
- Offered a number of Sondius Models.

Aureal ASP 301 Chip (1995-1997)



- Targeted for Sound Cards
- Hardware implementation of Digital Waveguide
- A version of the electric guitar ran on this chip

GeoShred (2015)

- Physically modeled guitar
- Highly expressive playing surface
- Intelligent pitch rounding
- Modeled feedback
- Modeled effects
- Arpeggiator
- Finger vibrato slide
- Extensive editing capabilities
- Customizable control surface
- Alternate tuning and interval support



[Video Gallery](#)

Formant Synthesis (1937)

- Harmonic resonances that are the consequence of a complex resonant geometry, like a vocal tract.
- It's been known for a long time that the vocal tract can be modeled with a bellows, a reed, a number of different size resonators and special elements for the tongue, the mouth.
[See Exploratorium Vocal Vowels.](#)

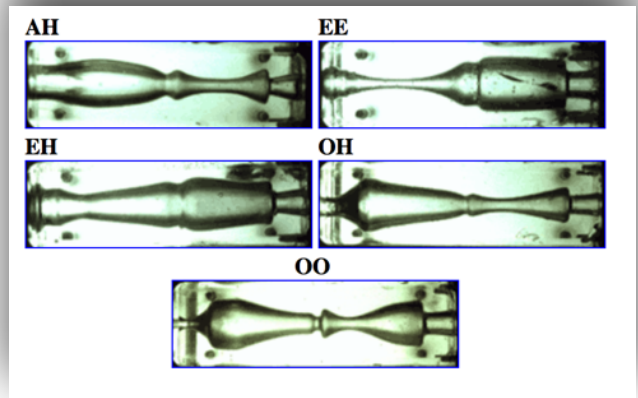
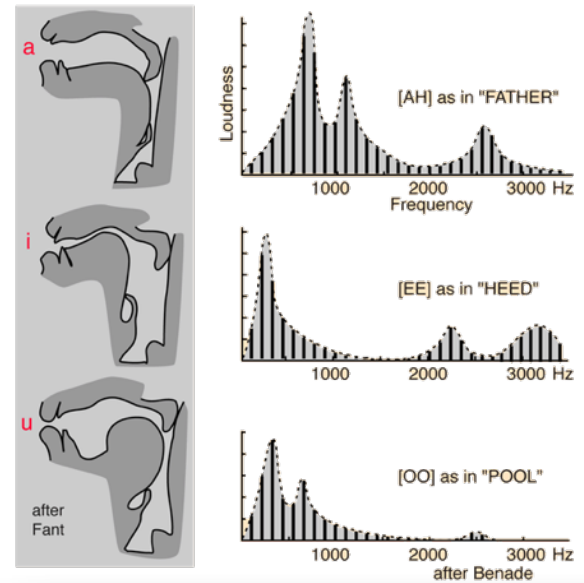

The Voder (1937-39) - Homer Dudley

- Analog Electronic Speech Synthesis
- Analog model of the vocal tract
- Develop from research on voice compression at Bell Labs.
- Featured at the 1939 Worlds fair
- [YouTube](#)

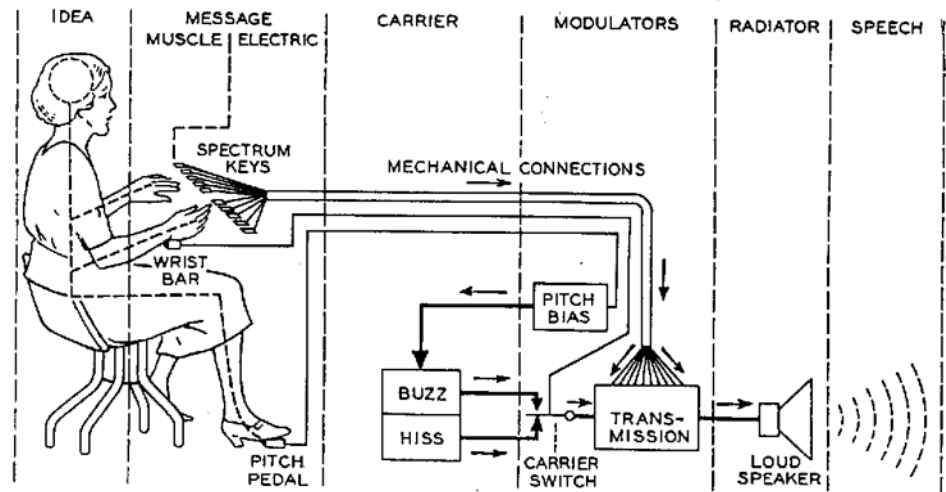
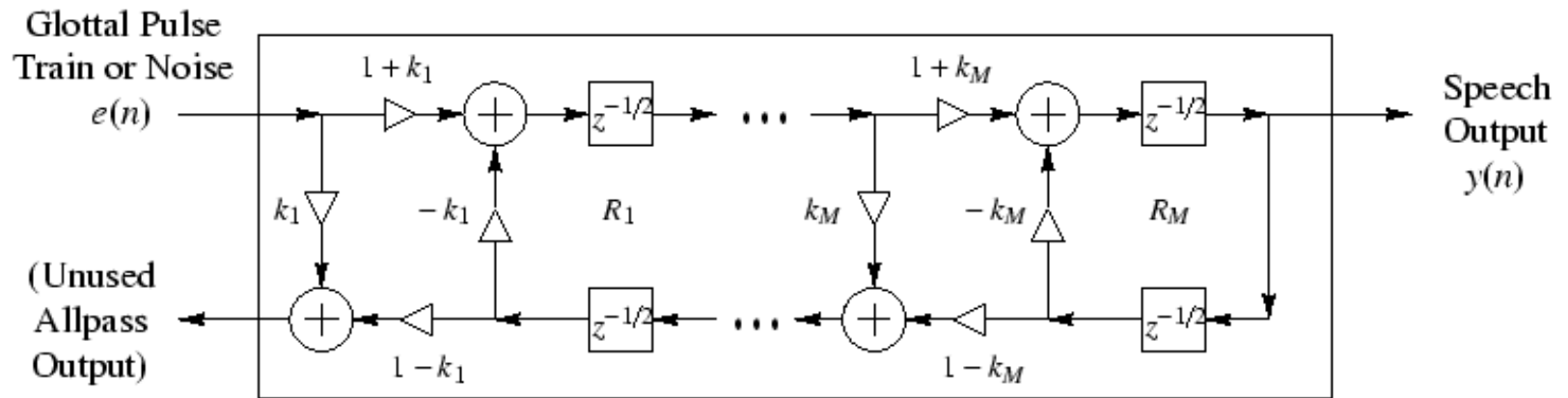
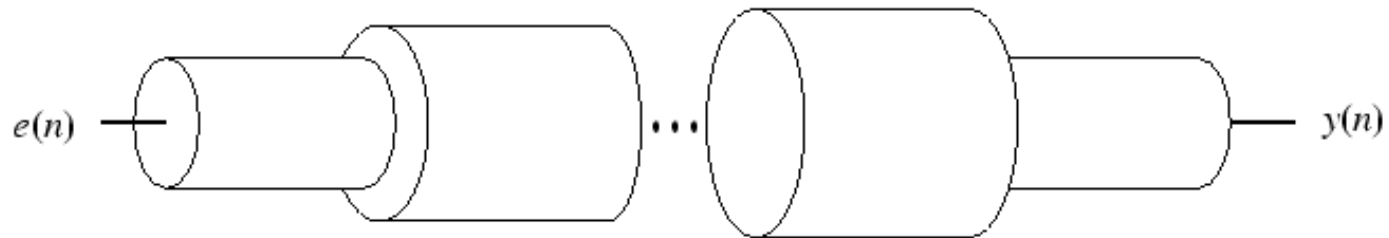

Fig. 8—Schematic circuit of the voder.



Kelly-Lochbaum Vocal Tract Model (1961)



Kelly-Lochbaum Vocal Tract Model (Piecewise Cylindrical)

Daisy Bell (1961)

- Daisy Bell ([MP3](#))
- Vocal part by Kelly and Lochbaum (1961)
- Musical accompaniment by Max Mathews
- Computed on an IBM 704
- Based on Russian speech-vowel data from Gunnar Fant's book
- Probably the first digital physical-modeling synthesis sound example by any method
- Inspired Arthur C. Clarke to adapt it for "2001: A Space Odyssey" the Hal 9000's "first song"

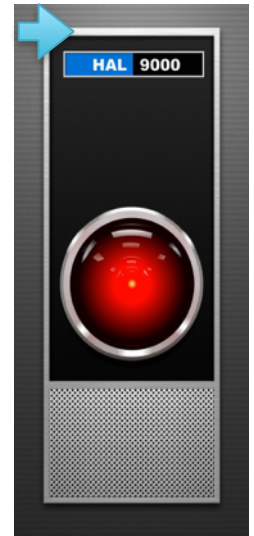

Vocoding (1937)

- Analysis and resynthesis
- The Voder (1937-1939)
- SIGSALY Speech Encryption (1941-1943)
- Moog Vocoder (1968)
- Moog/Wendy Carlos Vocoder - [“Clockwork Orange”](#) (1970)
- Kraftwerk “Autobaun” (1974)
- Alan Parsons Project - [“The Raven”](#) (1976)

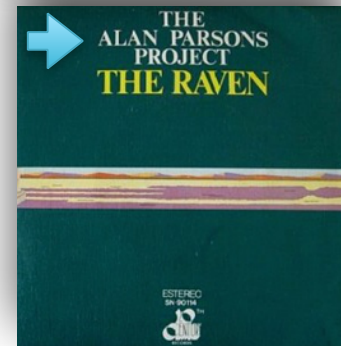

FM and Phase Distortion (1960s/1973)

- Buchla had Analog FM (mid 60s)
- Digital FM Developed by John Chowning, Stanford (1973)
- Licensed to Yamaha and New England Digital.
- Yamaha GS-1
- Yamaha DX-7
- Digital FM is actually phase modulation. Phase distortion Synth and Phase Modulation are equivalent mathematically.

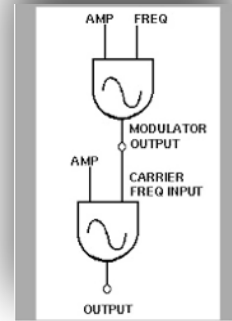
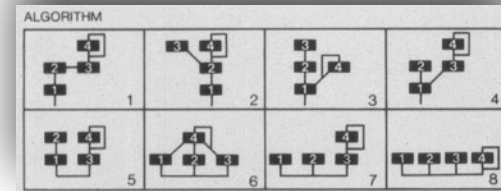

Granular Synthesis (1959)

- Iannis Xenakis (1959)
- Initially done with tape.
[“Analogique A-B for string orchestra and tape”](#) (1959).
- Small sample grains
- Graintable is a fusion of Granular and Wavetable



WaveTable (1980s)

- Lookup table of periodic waveforms.
- Often known waveforms (ie brass) are combined with filters and envelopes.
- Creative Labs marketed its sample based sound cards as “Wavetable” though they were really PCM samples.
- PPG Wave (1981) made extensive use of wavetable.



Spectral Modeling Synthesis (1980s)

- Similar to Vocoding. Analysis and resynthesis.
- Xavier Serra (1989) developed SMS.
- [Camel Audio's Alchemy](#) (2009)
- Native Instruments [Absynth](#) (2009)

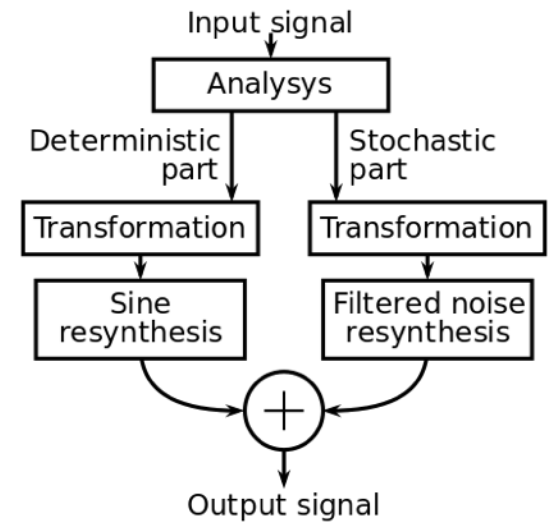

Vector Synthesis (1986)

- Sequential Circuits Prophet VS
- Later used by Yamaha in the SY22/TG33 and in some Korg products including the Wavestation.
- Dynamic crossfading between up to 4 sound sources

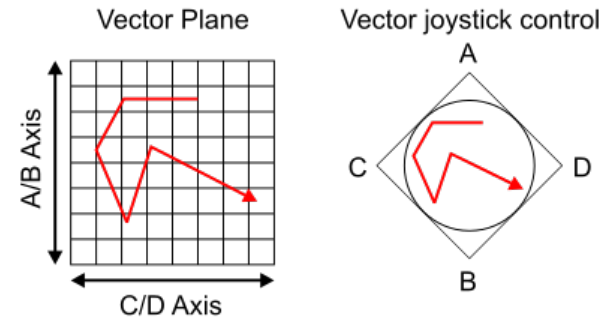

Linear Arithmetic (1987)

- Sampled attack (digital) + subtractive (analog)
- Roland D-50
- [The sound of the 80s!](#)



Polyphonic Synthesis



- Octave Dividing (OD) vs Voice Allocation (VA)
- Hammond Novachord (1939)
- Yamaha GX-1 (only 100 made)
KE used on Fanfare (1973)
- Oberheim 4 Voice - VA (1975)
- Polymoog - OD (1975)
- Prophet 5 - VA (1978)



Computer Music

- Music-N (1957 - 1982)
 - Max Matthews
 - First code for generating digital audio waveforms
 - Mathew's concepts, lookup tables, scheduler, are the norm for most hardware and software synthesis and audio DSP systems today
 - Many decedents: Max/MSP, Pure Data, AudioMulch, SuperCollider, JSyn, Common Lisp Music, Chuck
- Cound (1985)
 - Barry Vercoe
 - Branched from Music 11, but written in C



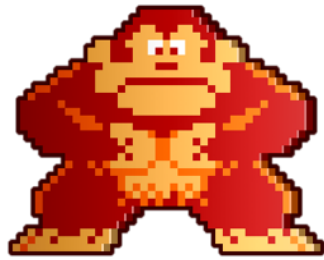

Game Music



- PSG (Programmable Sound Generators) Chips (1977)
- OPL(n) (1990)—FM Sound Chips.
 - The OPL2 chosen for the MPC spec.
 - Became the standard for sound cards
 - FM based Video game Music
- Wavetable
 - 4th generation SoundBlaster (1994)
 - MIDI/PCM based music for games.
- General MIDI (1991) - Standard voices for MIDI music
- SoundFonts, DLS (1990) - Downloadable sounds.

Ad Hoc Electronics

- Forbidden Planet - Bebe and Louis Barron (1956)
- BBC Radiophonic Workshop
 - Daphne Oram - Ormics (1957)
 - Delia Derbyshire - [Dr. Who Theme by Ron Granier \(1963\)](#)
- [PAIA](#) - DIY Synth and circuit kits
- Modern Circuit Bending



MIDI (1983)



Big topic :-)

OSC (1994, 1997)

- Open Sound Control
- Evolved from ZIPI
- developed at [CNMAT](#) by Adrian Freed and Matt Wright
- Higher resolution (32 bit floating point), richer parameter space
- Open Ended URL like syntax to address control elements
- Minimal semantics. There is no standard namespace in OSC for interfacing e.g. a synth;
- Some work in progress to define SYN a standard name space for controllers.
- Dozens of SW/HW products support OSC.



Modern Devices

- Haken Continuum
- Linnstrument
- Kaossilator
- Eigen Harp
- Alpha Sphere
- Roli Seaboard
- Tablets
- DJ Pads

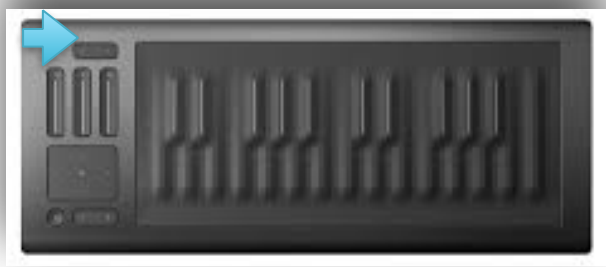
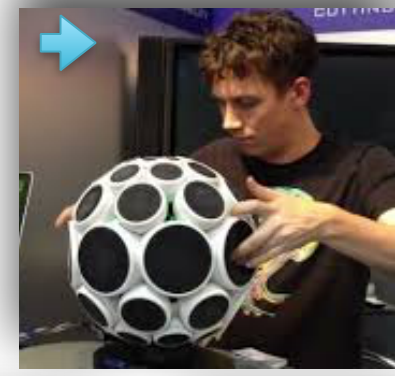

Future Of Electronic Musical Instruments



Future Of Electronic Musical Instruments

- EuroRack Retro Futurism
- Virtual Instruments
- Physical Modeling
- DJ driven interfaces
- Unique Controllers
MIDI/OSC
- As yet to be explored
new techniques

