

Using Physical Models to Make Sounds

Pat Scandalis
 Dr. Julius O. Smith III
 Nick Porcaro

Music Hackspace 4/20/2020

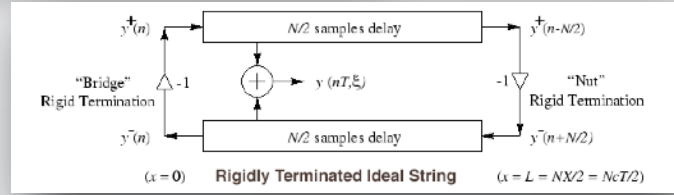
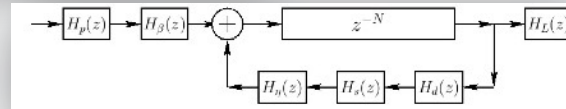
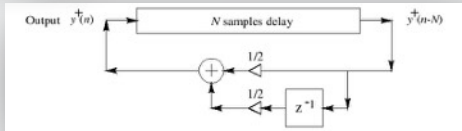
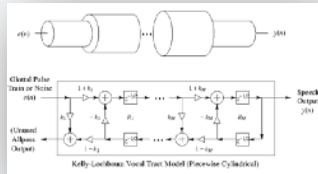

Our Full Deck on Physical Modeling Technology:

The Full Physical Modeling Deck:

<http://www.moforte.com/namma3e-physical-modeling-deck/>

Or

Go to the “News and Media” section at

<http://www.moforte.com>

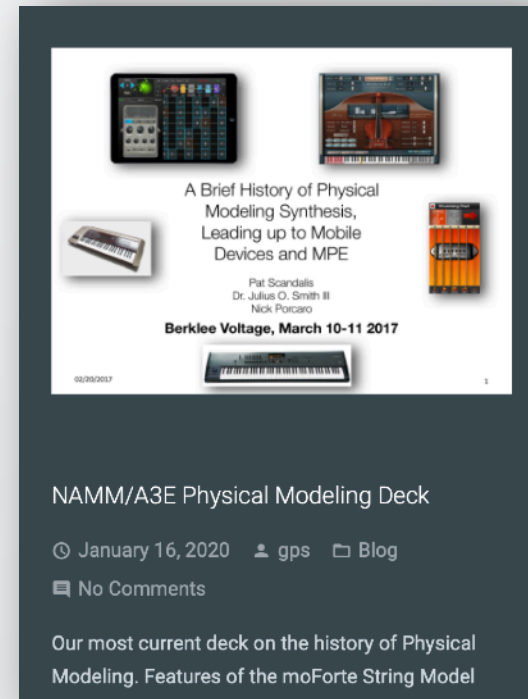
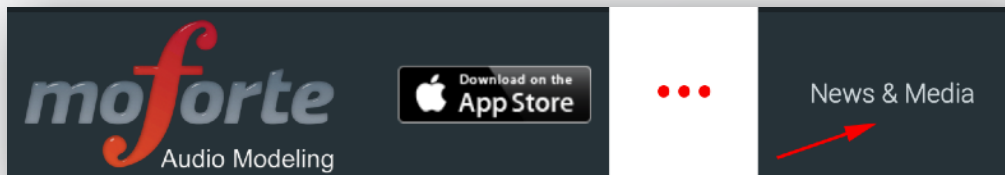

About Pat

- 36 years in the Silicon Valley as an Engineer
- Built my first monophonic electronic instrument from a Radio Shack kit in 1970
- Gigged with an Arp Avatar guitar synth (1978)
- Computer modeling of vibrating strings and membranes for senior thesis in Physics (1982)
- Researcher in Physical Modeling at Stanford/CCRMA (1994)
- CEO/CTO of moForte



Why Physical Modeling?

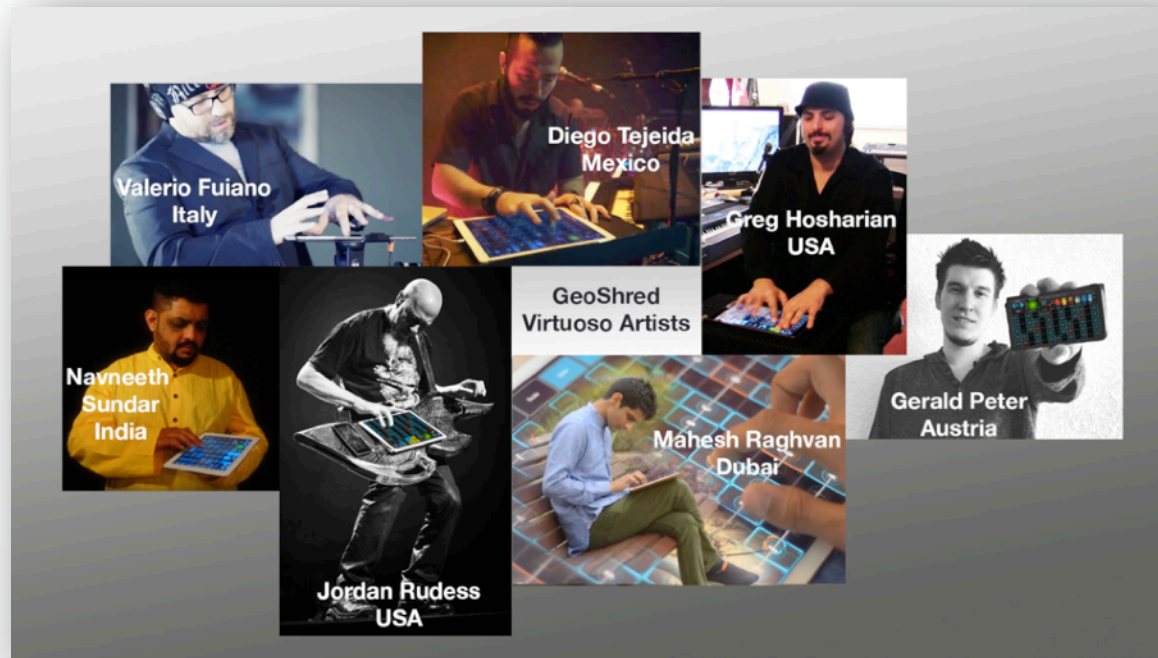

As performing musicians, what we do, is translate emotional expression, feelings, into musical performance. PM and EM instruments models can give performers expressive controls that can be used to project emotion to a listening audience.

It's About Musical Expression!

Musical Expression Taken To The Next Level



The Story

Technology - An abbreviated history of Physical Modeling Synthesis. Why in 1994, PM was poised to be the “Next Big Thing”.
And why it’s back!



What is Physical Modeling Synthesis?

- Methods in which a sound is generated using a mathematical model of the physical source of sound.
- Any gestures that are used to interact with a real physical system can be mapped to parameters yielded an interactive and expressive performance experience.
- **Physical modeling is a collection of different techniques specific to each sound generation process.**

$$\frac{\partial^2 y}{\partial t^2} = \frac{1}{v_w^2} \frac{\partial^2 y}{dt^2}$$

Physics + Math
物理 + 數學



Taxonomy of Modeling Areas

Hornbostel–Sachs Classification

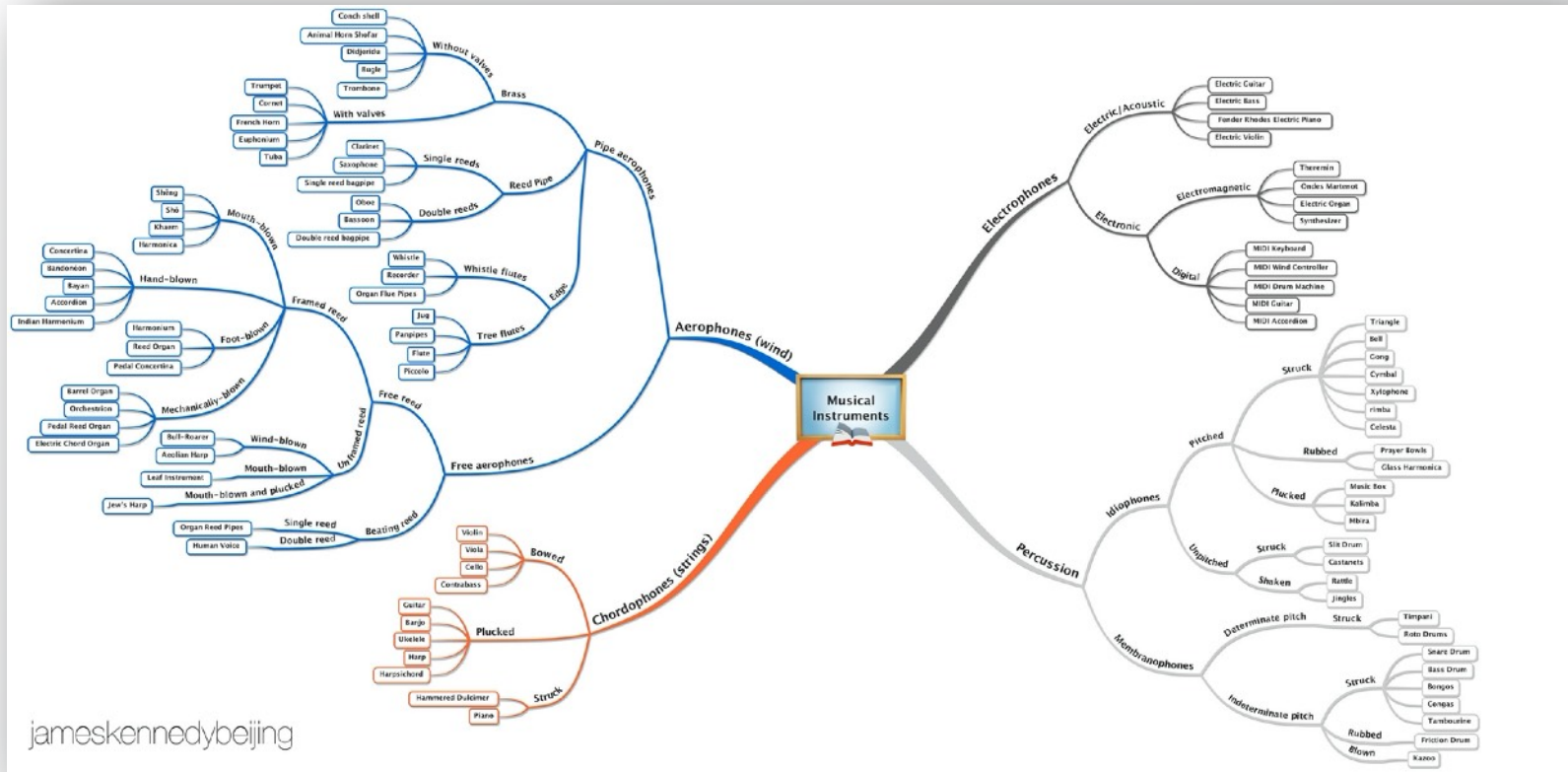

jameskennedybeijing

- Chordaphones - Guitars
- Aerophones - Woodwinds
- Membranophones - Drums

- Idiophones - Mallet Instruments
- Electrophones - Virtual Analog
- Game Sounds
- Voice

The Voder (1937-39) - Homer Dudley

- Analog Electronic Speech Synthesis
- Analog model of the vocal tract
- Develop from research on voice compression at Bell Labs.
- Featured at the 1939 Worlds fair

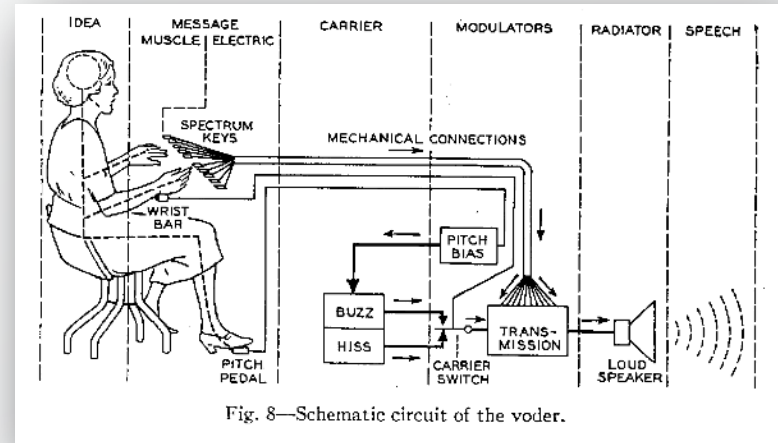

Kelly-Lochbaum Vocal Tract Model (1961)

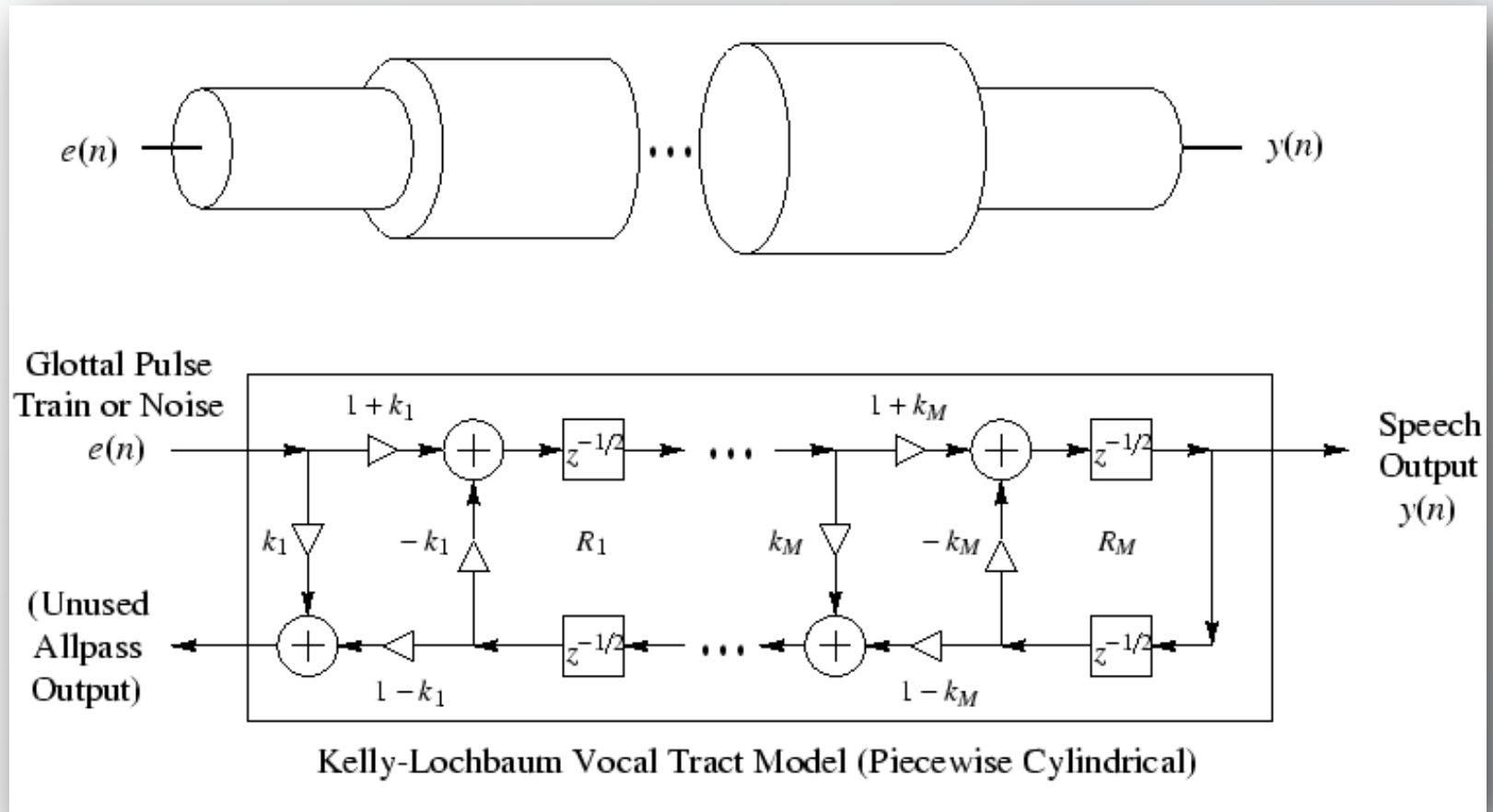

Daisy Bell (1961)

- Daisy Bell
- Vocal part by Kelly and Lochbaum (1961)
- Musical accompaniment by Max Mathews
- Computed on an IBM 704
- Based on Russian speech-vowel data from Gunnar Fant's book
- Probably the first digital physical-modeling synthesis sound example by any method
- Inspired Arthur C. Clarke to adapt it for "2001: A Space Odyssey" the Hal 9000's "first song"

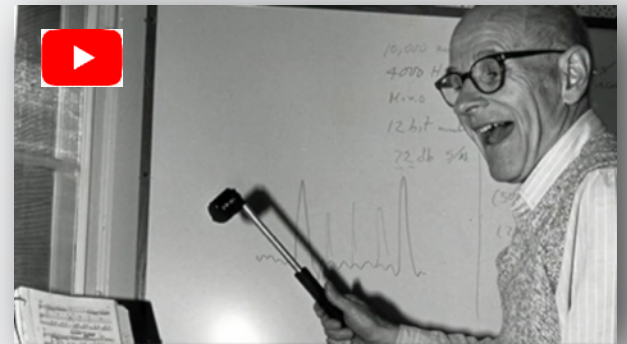

Karplus-Strong (KS) Algorithm (1983)

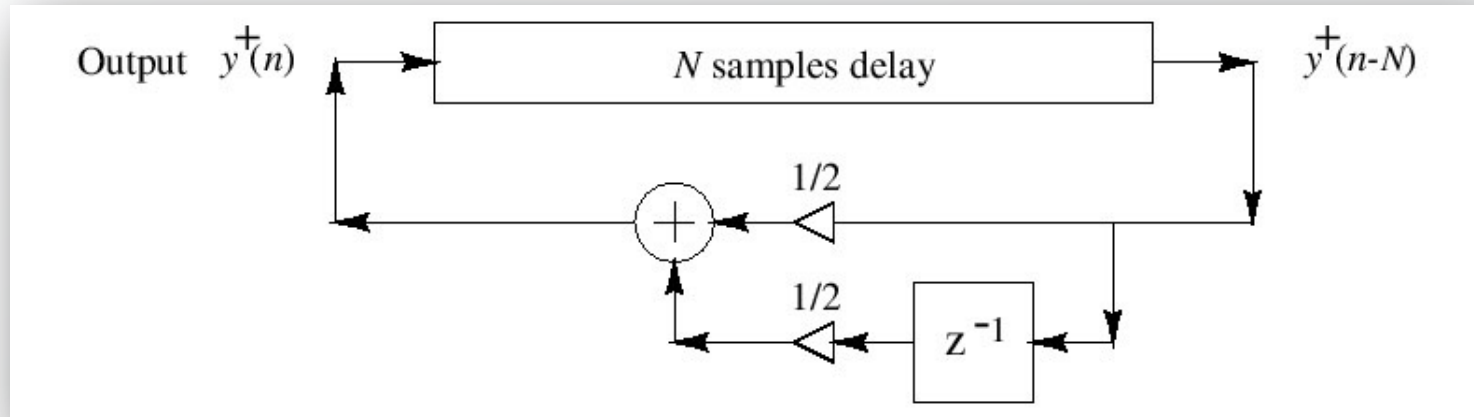

- Discovered (1978) as “self-modifying wavetable synthesis”
- Wavetable is preferably initialized with random numbers
- Licensed to Mattel
- The first musical use of the algorithm was in the work “*May All Your Children Be Acrobats*” written in 1981 by David A. Jaffe.



EKS Algorithm (Jaffe-Smith 1983)

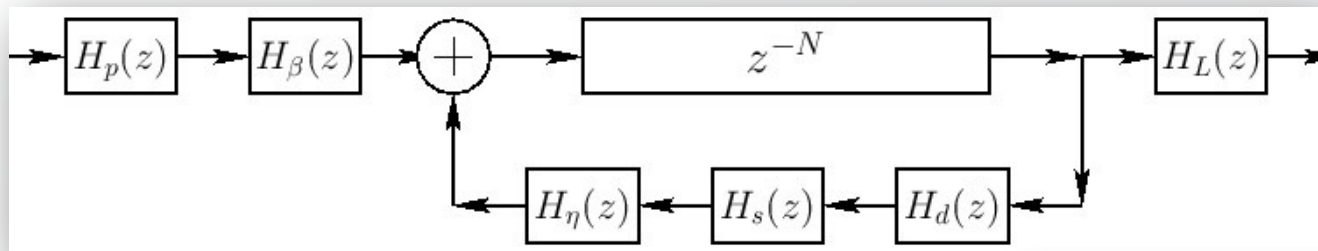

$$H_p(z) = \frac{1-p}{1-pz^{-1}} = \text{pick-direction lowpass filter}$$

$$H_\beta(z) = 1 - z^{-\lfloor \beta N + 1/2 \rfloor} = \text{pick-position comb filter, } \beta \in (0, 1)$$

$$H_d(z) = \text{string-damping filter (one/two poles/zeros typical)}$$

$$H_s(z) = \text{string-stiffness allpass filter (several poles and zeros)}$$

$$H_\eta(z) = -\frac{\eta(N) - z^{-1}}{1 - \eta(N)z^{-1}} = \text{first-order string-tuning allpass filter}$$

$$H_L(z) = \frac{1-R_L}{1-R_Lz^{-1}} = \text{dynamic-level lowpass filter}$$



- Musical Example “Silicon Valley Breakdown” (Jaffe 1992)
- Musical Example BWV-1041 (used to intro the NeXT machine 1988)

Digital Waveguide Models (Smith 1985)

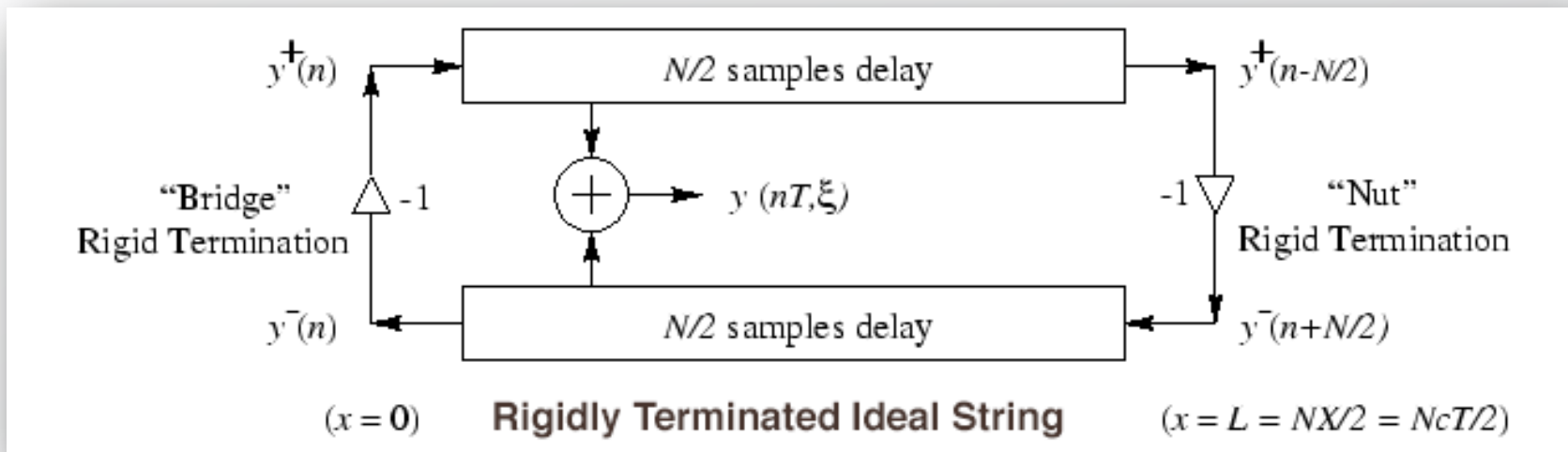

- Equivalent to d'Alembert's Solution to the Partial Differential Equation for a string (1747)
- Used for the Yamaha VL Family (1994)
- Shakuhachi, Tenor Sax



Digital Waveguide Models (Smith 1985)

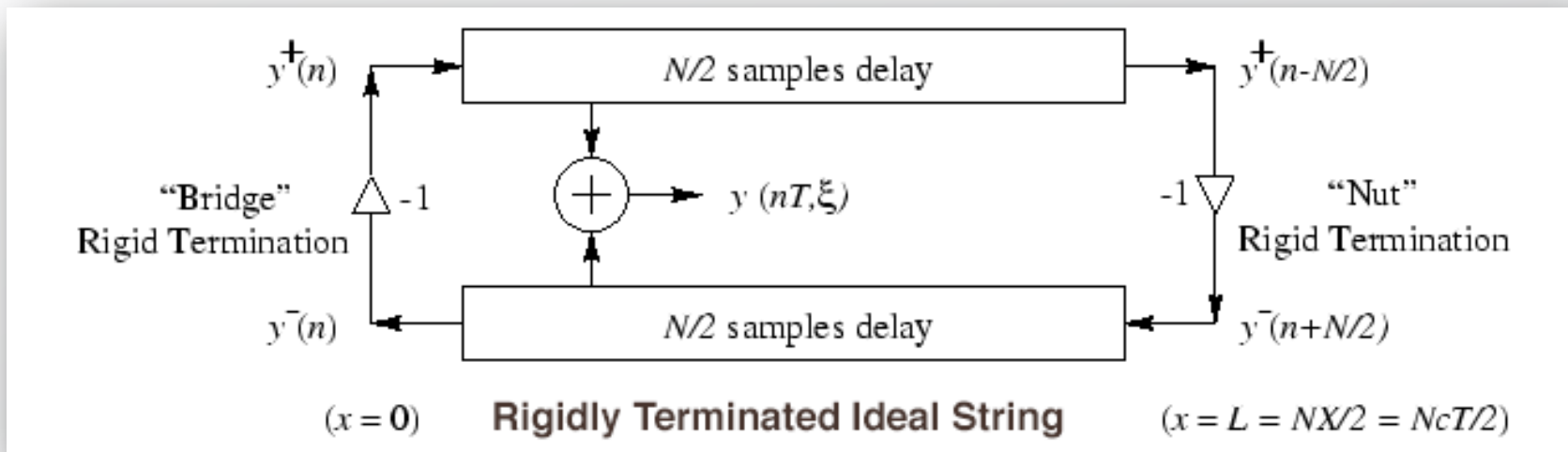

- Equivalent to d'Alembert's Solution to the Partial Differential Equation for a string (1747)
- Used for the Yamaha VL Family (1994)
- Shakuhachi, Tenor Sax



Stanford Sondius Project (1994-1997)



- Stanford OTL/CCRMA created the Sondius project to assist with commercializing physical modeling technologies.
- The result was a modeling tool known as SynthBuilder (Porcaro, et al.) , and a set of models covering about two thirds of the General MIDI set.
- Many modeling techniques were used including EKS, Waveguide, Commuted Synthesis, Coupled Mode Synthesis, Virtual Analog.

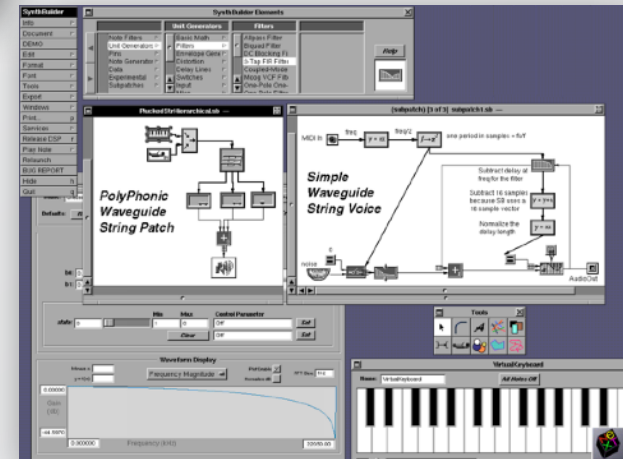

- Wind Chime Model ([MP3](#))
- Tubular Bells Model ([MP3](#))
- Percussion Ensemble ([MP3](#))
- Taiko Ensemble ([MP3](#))
- Piano ([MP3](#))
- Harpsichord ([MP3](#))
- Virtual Analog ([MP3](#))

Early Guitar Model (1996)



- Versions of the model have been around since 1996 (Sondius)
- Mobile devices with sensors and multi-touch screens created a new opportunity to create a performable, expressible version of the model.

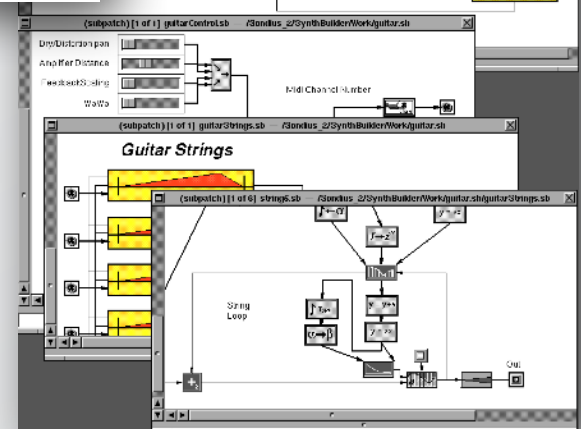
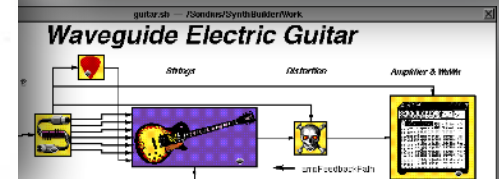
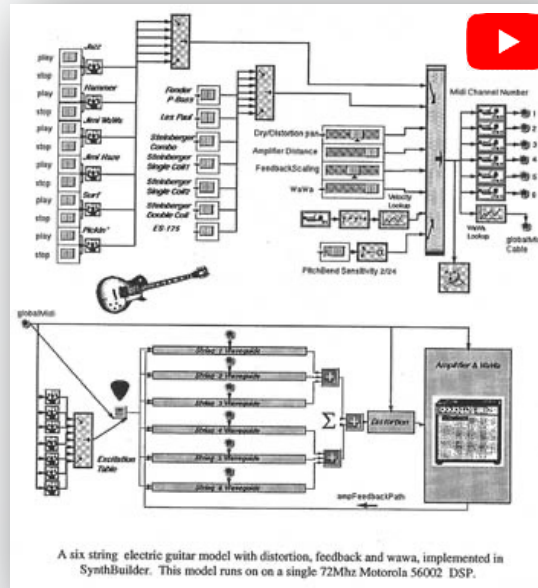

Early Guitar Model (1996)



- Versions of the model have been around since 1996 (Sondius)
- Mobile devices with sensors and multi-touch screens created a new opportunity to create a performable, expressible version of the model.

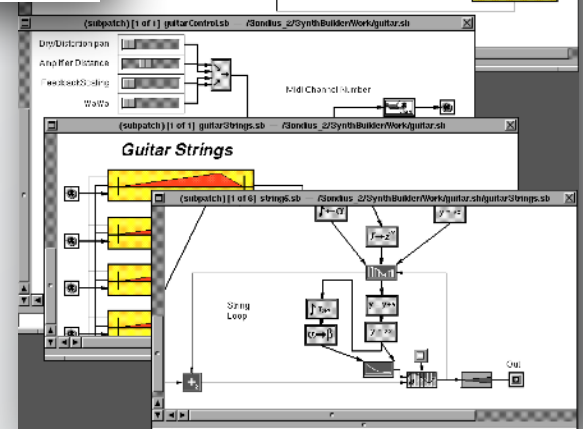
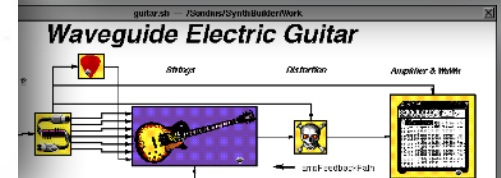
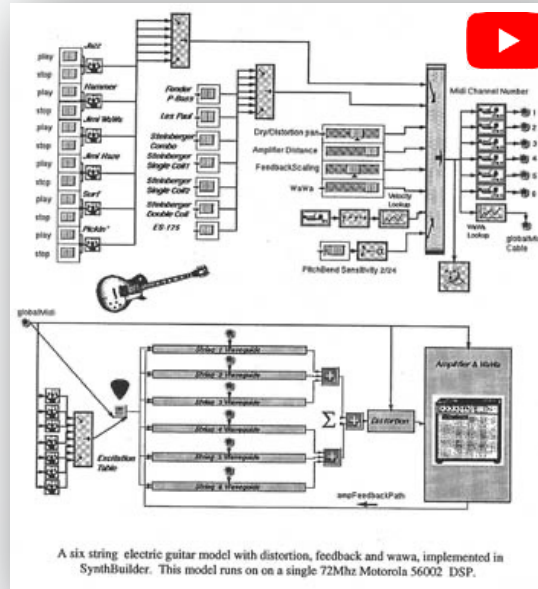

Virtual Analog (Stilson-Smith) (1996)

- Alias-Free Digital Synthesis of Classic Analog Waveforms
- Digital implementation of the Moog VCF. Four identical one-poles in series with a feedback loop.
- Sounds great!

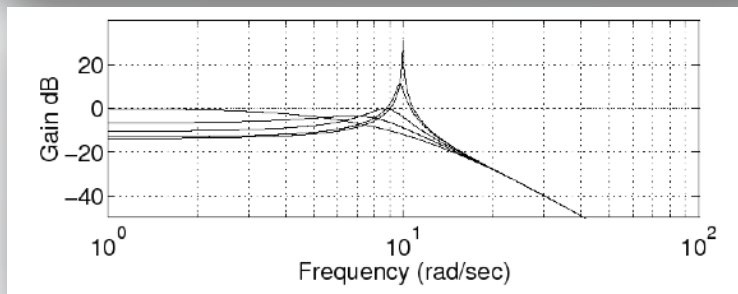
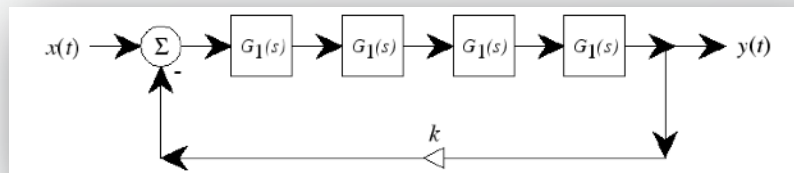

Full Ensembles all Physical Modeling (1997)



- Stanford OTL/CCRMA created the Sondius project to assist with commercializing physical modeling technologies.
- The result was a modeling tool known as SynthBuilder, and a set of models covering about two thirds of the General MIDI set.
- Many modeling techniques were used including EKS, Waveguide, Commuted Synthesis, Coupled Mode Synthesis, Virtual Analog.

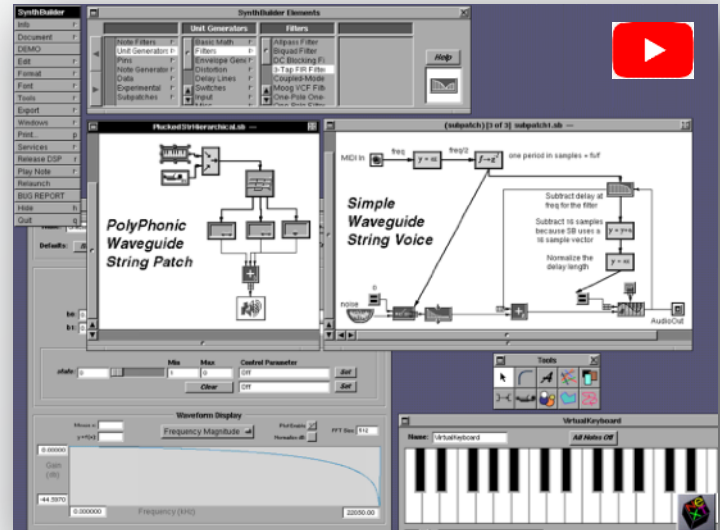

Full Ensembles all Physical Modeling (1997)



- Stanford OTL/CCRMA created the Sondius project to assist with commercializing physical modeling technologies.
- The result was a modeling tool known as SynthBuilder, and a set of models covering about two thirds of the General MIDI set.
- Many modeling techniques were used including EKS, Waveguide, Commuted Synthesis, Coupled Mode Synthesis, Virtual Analog.

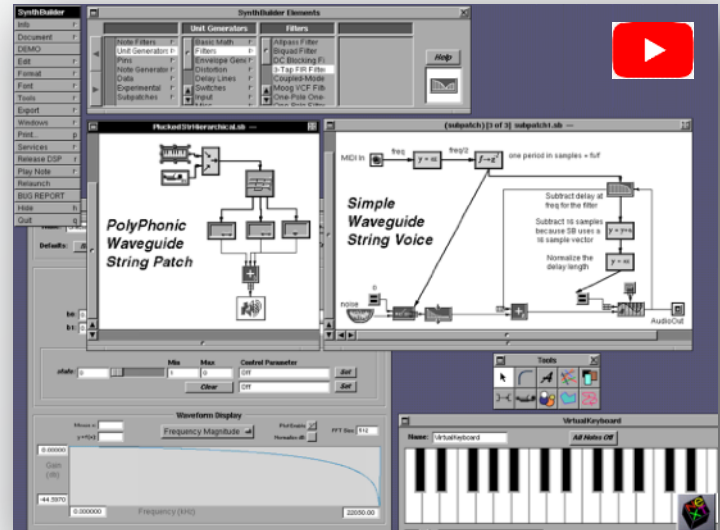

First Generation PM Products

- Yamaha VL-1 + Chipsets (1994-2000)
- Korg SynthKit ... Kronos (1994-present)
- Seer Systems Reality (1997)
- Aural ASP 301 Chip (1995-1997)
- Staccato SynthCore Sondius Models (1997-2001)



In 1994 Physical Modeling Was Poised to be the “Next Big Thing”. So What Happened?

- By 1994, FM was the standard for PC Game Music. In part due to it's small memory footprint.
- PM was seen by Yamaha as the successor to FM (John Chowning's pioneer FM patent was expiring).
- The cost of memory starting plummeting in 1996. Sampling became common.
- Some expressivity could be achieved with extensively interpolated samples.
- Voicing PM is difficult (like FM), voicing samples is more direct.
- Controllers that could express multiple dimensions were not common.



Why is PM Back?

- **“The Glass”** - Multi-touch, lots of sensors, mobile devices are everywhere; great for parametrically controlled, physically modeled musical instruments
- **MPE** - There is a new generation of polyphonic expressive controllers based on the new MIDI MPE spec.





MIDI Polyphonic Expression

- MPE spec was adopted January 2018
- A set of **conventions built on MIDI 1.0** to communicate multidimensional control data.
- Until recently, the options for expressing musical parameters typically affected all notes the same way. **MPE is a standard for expressive control on a per-note or per-string basis.**
- Already adopted by over 50 hardware and software products.
- MPE combined with PM, the sum is greater than the parts.

Performance Surface and Musical Expression

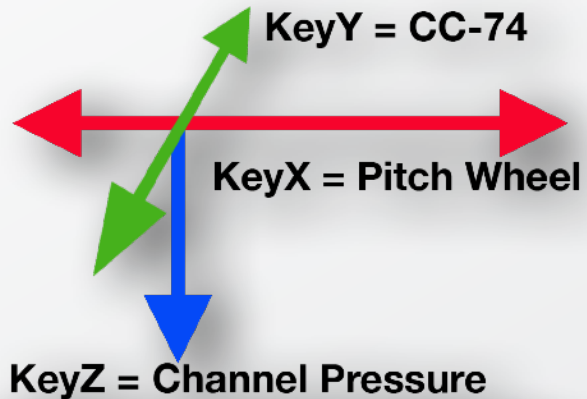

MPE in a Nutshell

- Derivative of Multi Mode (MIDI Mode 5), enabled with RPN-6.
- Can be Channel-Per-Note (for Keyboards, like the Seaboard) or Channel-Per-Row (String) (GeoShred, LinnStrument, Guitar Controller).

- Expression Control Conventions.
 - KeyX – Pitch Bend (Roli calls this *Glide*)
 - KeyY – CC-74 (Roli calls this *Slide*)
 - KeyZ – Channel Pressure (Roli calls this *Press*)

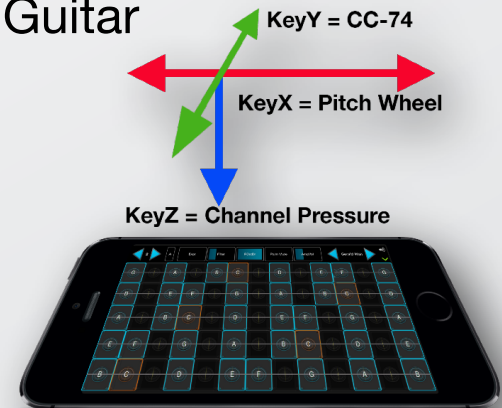

- Provides for master channels (typically 1 or 16) that globally control the MPE voice channels. (ie modWheel to all voice channels)
- Provides for a low/high split, and each split can have it's own master channel.

MPE Controllers

- LinnStrument
- Seaboard
- GeoShred
- KMI K-Board Pro 4
- Haken Continuum
- Artiphon INSTRUMENT 1
- Sensel Morph
- Joué

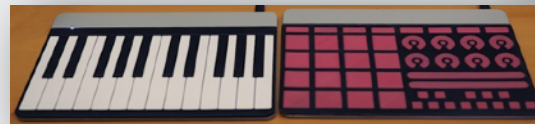
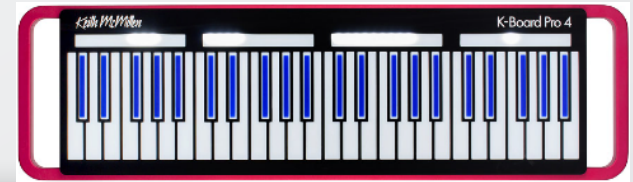
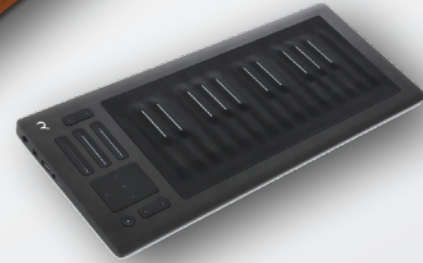
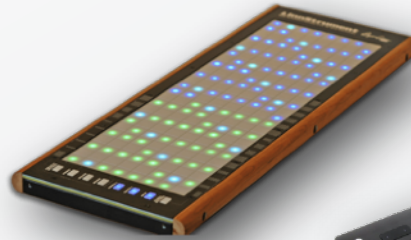

MPE Modeled Synths

- GeoShred



- SWAM



- Animoog/Model 15



MPE/Model Demos

- [GeoShred Controlling SWAM Sax \(Jordan Rudess\)](#)
- [Seaboard and LinnStrument controlling GeoShred](#)
- [Seaboard Controlling GeoShred \(Gerald Peter\)](#)
- [GeoShred with MPE KeyZ using 3D Touch \(Gerald Peter\)](#)

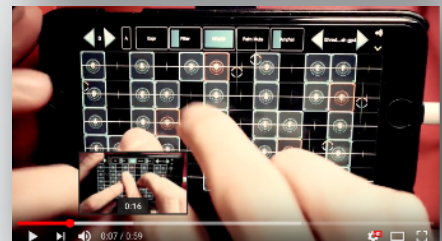
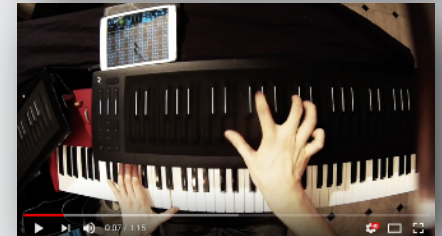
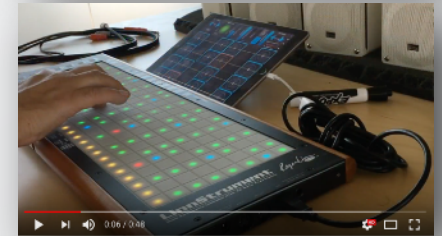
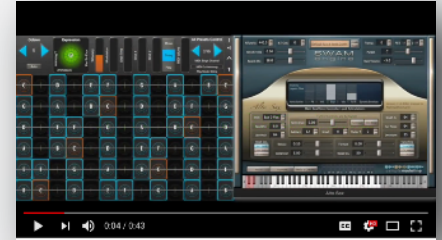

Imagine a new kind of musical instrument ...



An instrument where a performer can fluidly express multiple independent voices ... fingers. An instrument that is both pitch fluid, and helps the performer precisely reach desired musical pitches in any temperament.

This is GeoShred



GeoShred is an award winning, fluidly expressive musical instrument that runs on multi-touch devices. It has a unique **performance surface** with an “almost magic” pitch rounding algorithm, which is paired with a **physical model** of the physics of strings. Further, it’s unique expressive control can be used to control other synthesizers.

GeoShred's Expressive Control Used with other Synthesizers

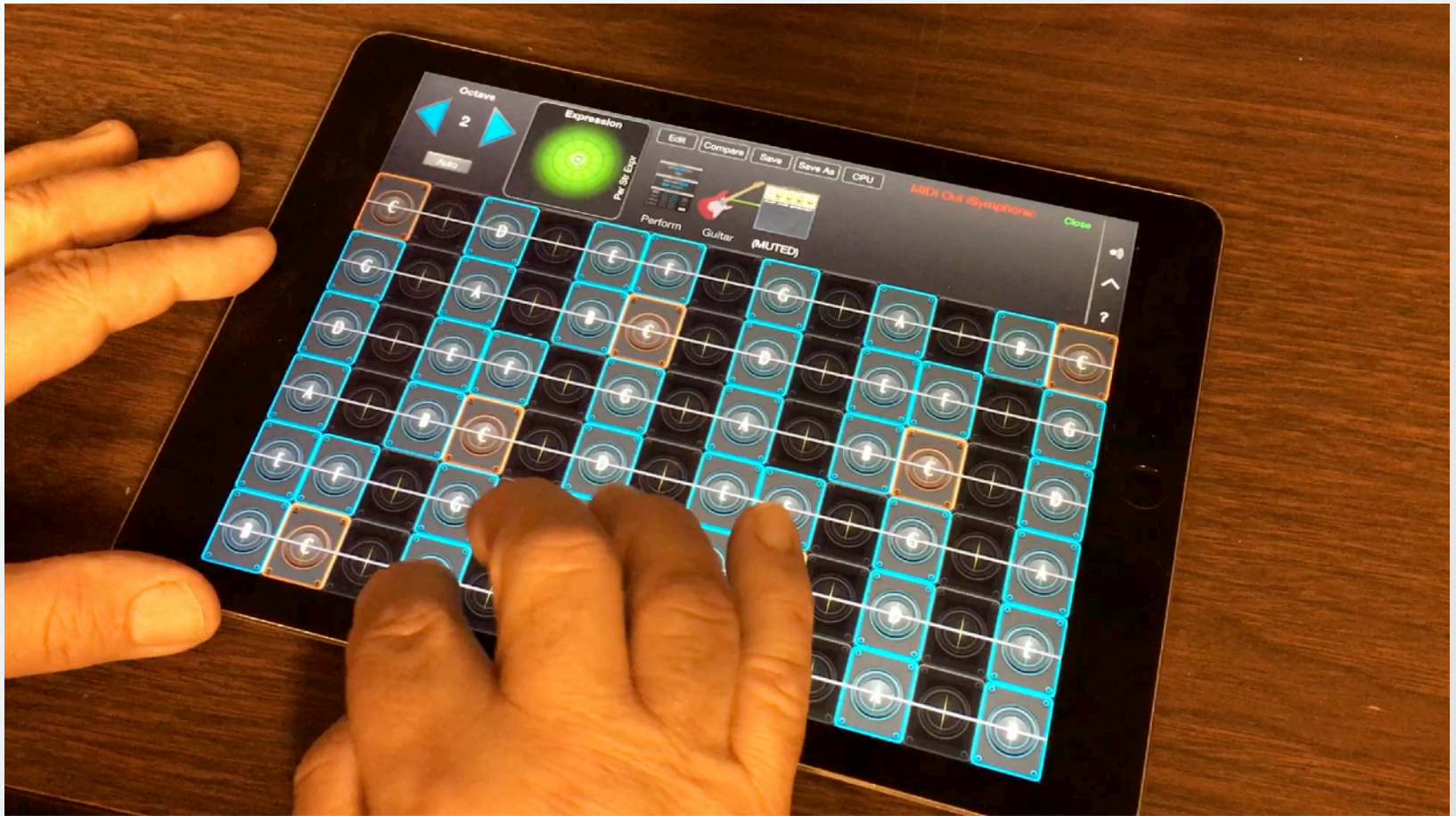

Thanks!

- Mary Albertson
- Simone Capitani
- Chris Chafe
- John Chowning
- Perry Cook
- Jon Dattorro
- David Jaffe
- Joe Koepnick
- Romain Michon
- Denis Labrecque
- Scott Levine
- Fernando Lopez-Lezcano
- Yann Orlarey
- Stephane Letz
- Stanford OTL
- Danny Petkevich
- Nick Porcaro
- Bill Putnam
- Danielle Rudess
- Jordan Rudess
- Kent Sandvik
- Pat Scandalis
- Dr. Julius O. Smith II
- Tim Stilson
- Jean-Baptiste Thiebaut
- David Van Brink
- Scott Van Duyne
- Yamaha



And CCRMA