

GeoShred

A New Kind of Musical Instrument



Pat Scandalis
Jordan Rudess
Dr. Julius O. Smith III
Nick Porcaro

CTO, moForte
Rock Star, President Wizdom Music
Professor Stanford/CCRMA
Chief Scientist, moForte

Imagine a new kind of musical instrument ...



An instrument where a performer can fluidly express multiple independent voices ... fingers. An instrument that is both pitch fluid, and helps the performer precisely reach desired musical pitches in any temperament.

This is GeoShred



GeoShred is a fluidly expressive musical instrument that runs on multi-touch devices. It has a performance surface with an “almost magic” pitch rounding algorithm, which is paired with a model of the physics of strings. And it’s expressive control can be used with other synthesizers.

Tens of Thousands of Artists in 48 Countries Perform GeoShred

Props

"GeoShred is brilliant- it's a real instrument."
– Eddie Jobson - Roxy Music, Jethro Tull,
Frank Zappa, UK

"A fantastic new invention which is going to revolutionize the way music is played, expressed and learned! 'GeoShred' is one of the foremost best musical inventions I've had the pleasure to experience in recent years.

Definitely 5 stars out of 5!
GIGANTASTIVISSIMO.....R...A...Z !!!!!
– Patrick Moraz, Yes, Moody Blues

"That's just nuts. You're [Jordan] the best-guitarist-without-a-guitar of all time."
– Joe Satriani

"GeoShred is a breakthrough [musical instrument] for the iPad. Some might think it's the best evidence yet that there has indeed been reverse engineering of alien technology, but if that's the case, then aliens play guitar... and worship Jimi Hendrix."

– Craig Anderton, Harmony Central,
Founding Editor Electronic Musician
Magazine

"...one of the most innovative, groundbreaking products to emerge in the past twelve months"
– Electronic Musician, 2017 Editor's Choice

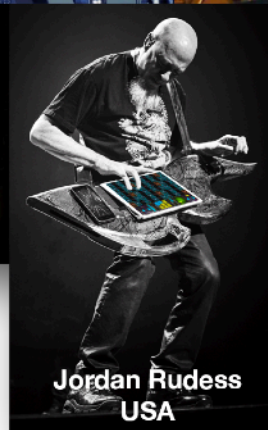
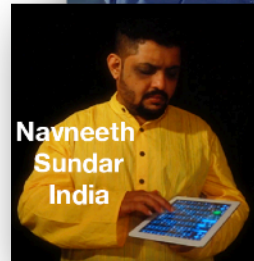
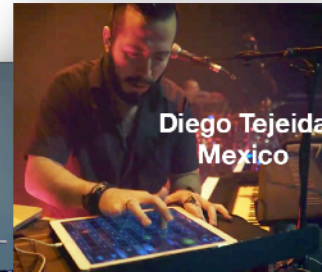
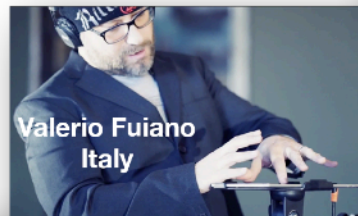

**27% of GeoShred Users
are in India**

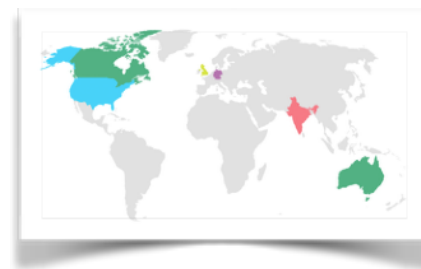

The Artists



GeoShred
Virtuoso Artists



The GeoShred Story

- **History**
Merging technology from two sources
- **The Design Language**
Principles used in creating the instrument
- **Musical Expression**
What is special about GeoShred
- **The Physical Model of Strings**
Expression opportunities
- **Pro Features**
Bringing GeoShred's expression to other synths

History



GeoShred is a collaboration between Rock Star and mobile music innovator Jordan Rudess, Stanford/CCRMA Professor Dr. Julius O. Smith III, Nick Porcaro and Pat Scandalis



A Fusion of Ideas

GeoShred is a fusion of Jordan's musical performance ideas from an earlier instrument (Geo Synthesizer) and advanced DSP models of the physics of strings that Julius, Nick and Pat have been working on for the past 35 years

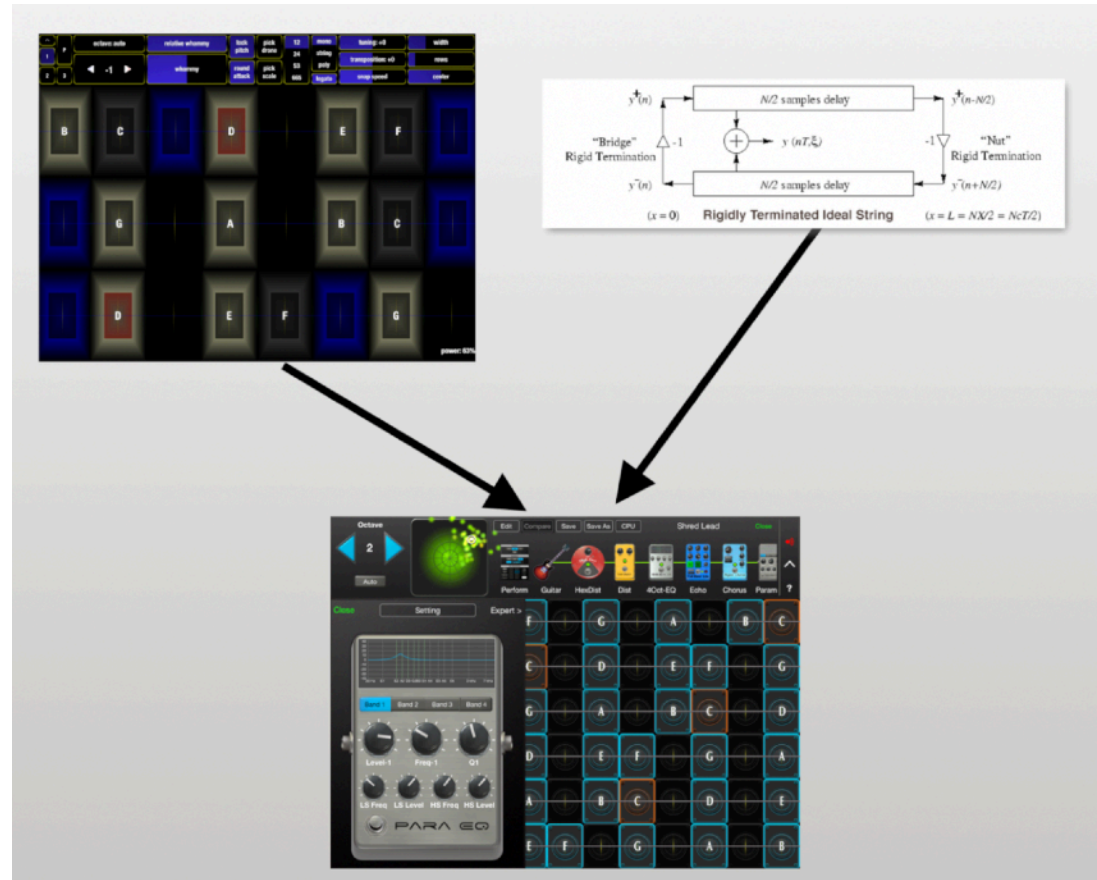

Early Guitar Model (1996)

- Versions of the model have been around since [1996](#)
- Mobile devices with sensors and multi-touch screens created a new opportunity to create a performable, expressible version of the model.

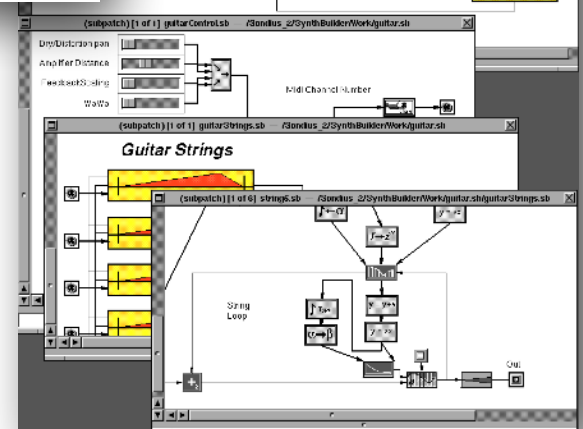
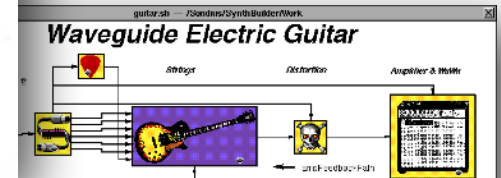
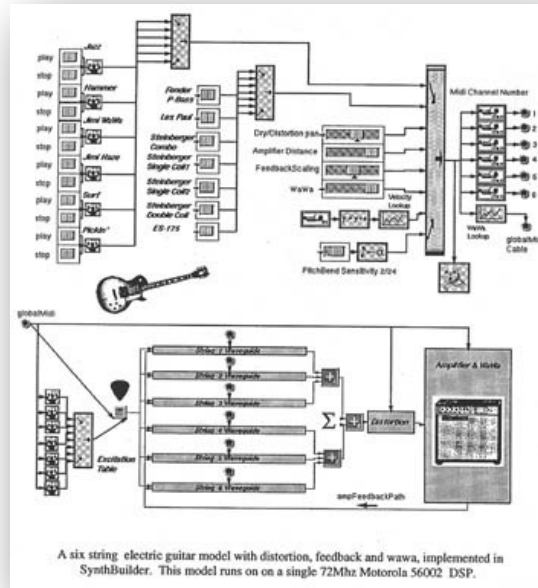

Geo Synthesizer (2011)

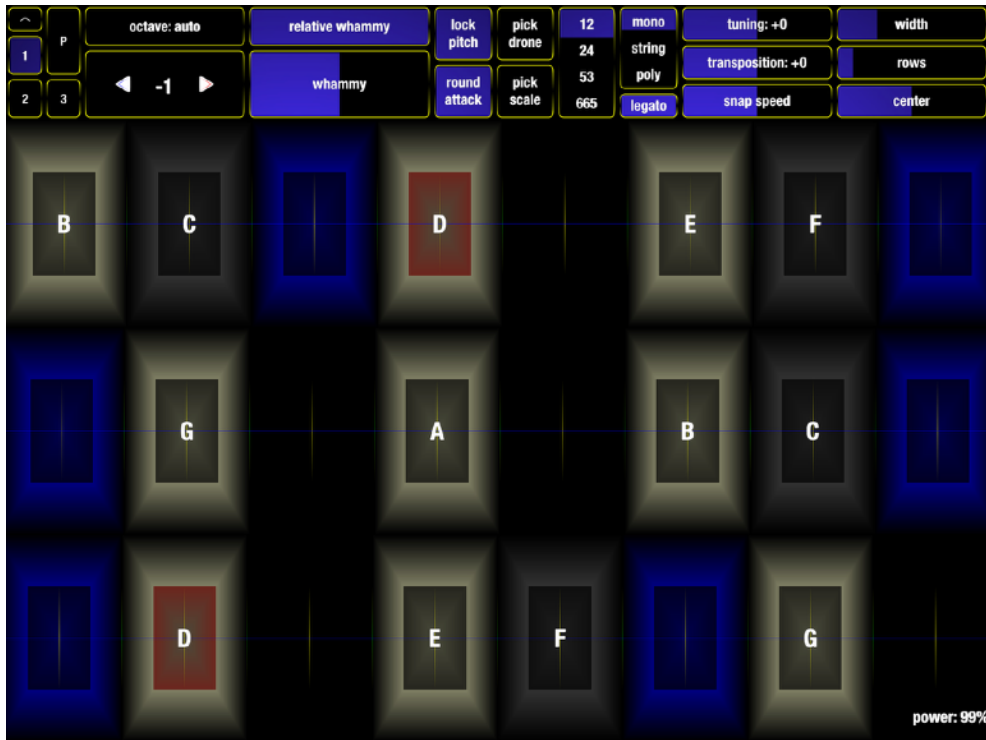

Jordan's ideas about a fluid multi-touch instrument, with pitch rounding were realized in 2011 with Geo Synthesizer, based on sampling.

Design Language

Principles Used in Creating The Instrument

- We had a “definite” list of things the instrument should be able to do.
- We embraced agilism and declared Jordan to be the “Sacred User”. His thoughts on the interface were based on daily builds. Sometimes he would give us feedback based on his most immediate stage experience.
- Simple things should be simple, difficult things should be possible. - Julius
- A fusion of flat and skeuomorphic design, based on direct user feedback. Example, the users relate to the skeuomorphic stomp boxes because the interaction language is known.

Musical Expression



Pitch Expression

- The GeoShred Keyboard has a pitch rounding feature that makes it possible to play in tune while sliding fluidly on the glass.
- Initial touches are always in-tune.
- Sliding will seek toward being in-tune.
- Pitch Rounding can be turned off to enable full microtonal performing.

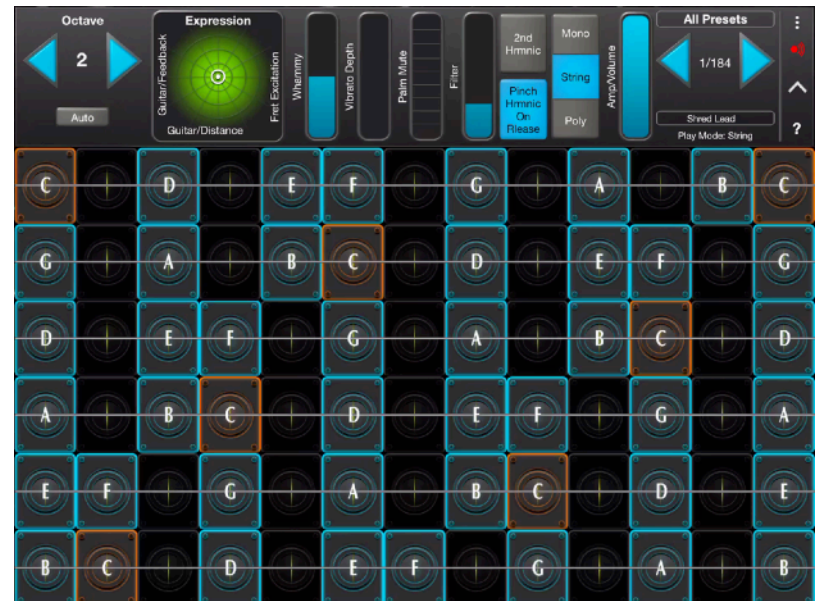
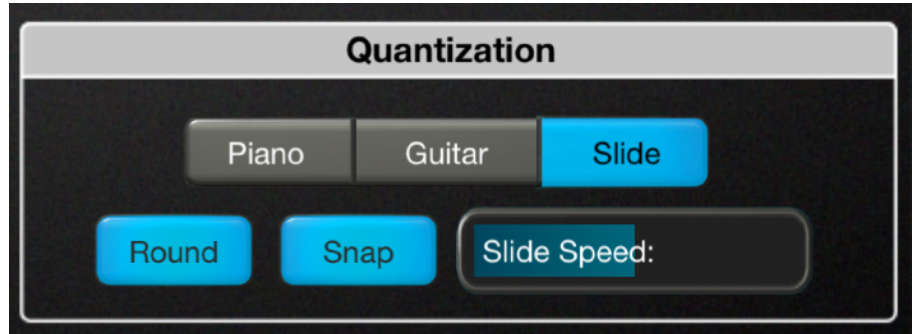

Keyboard

- Tuned in 4ths, but can be any tuning
- Variable number of strings and frets

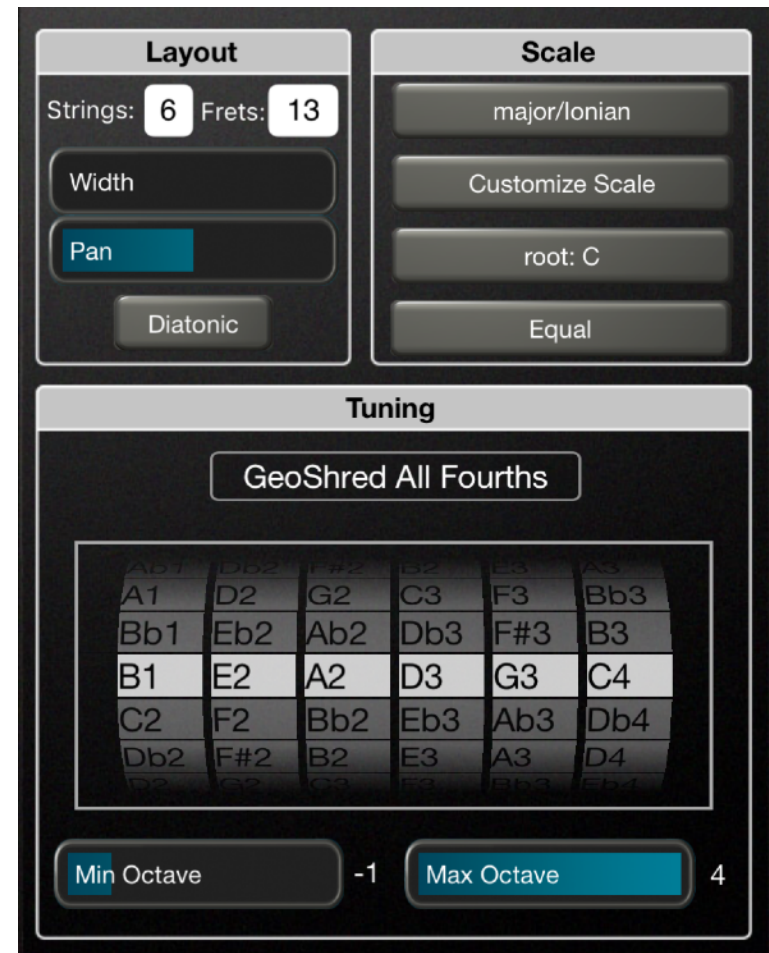
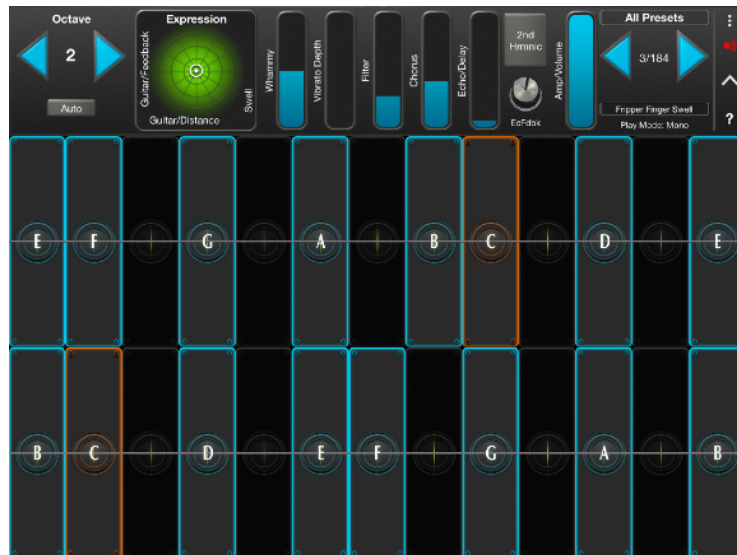

Keyboard

- Any scale, including over 200 ragas
- Any Temperament

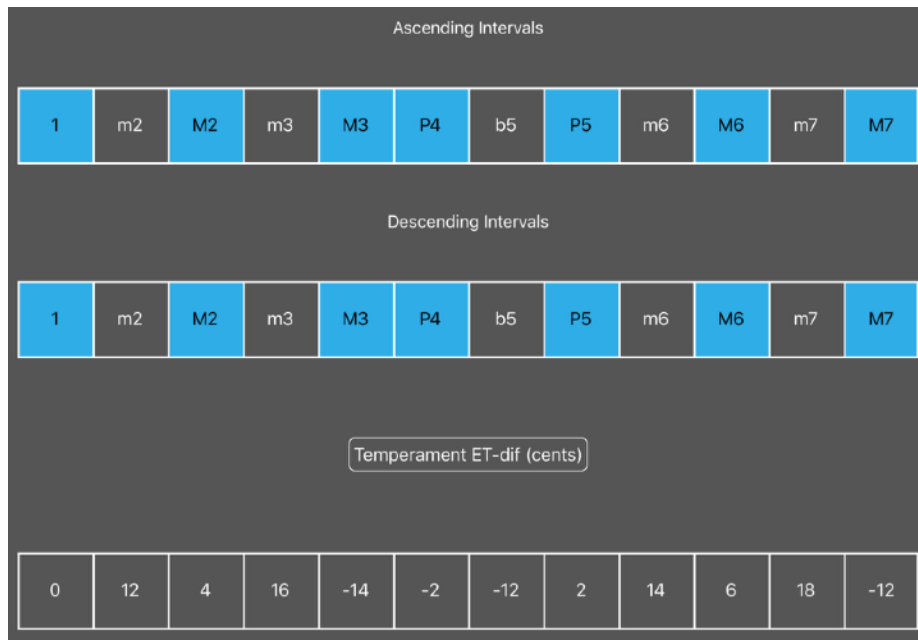

Andholika
Arabhi
Asavari
Asavari (Carnatic)
Atana
Bageshree
Bahar
Bahudhari
Bairagi
Bangala
Basant
Basant Mukhari
Begada
Behag
Behag Deshikam
Bhairav
Bhairavi
Bhairavi North Indian
Bhatiyar
Bhavapriya
Bhimpalasi

Diatonic Keyboard

- Only notes in the scale
- Pitch rounding works with non-uniform intervals.
- Makes it possible for more people to play GeoShred

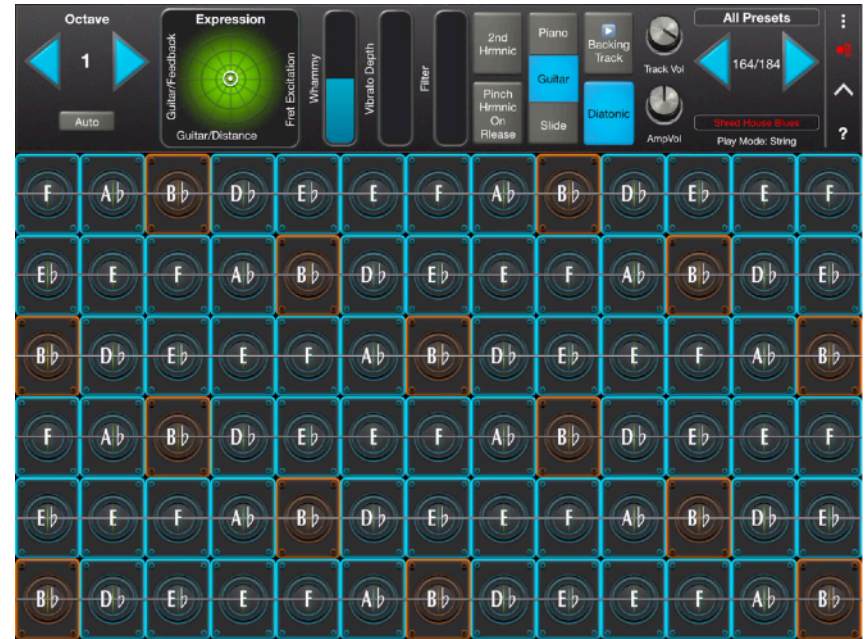

The Physical Model of Strings (and Effects)

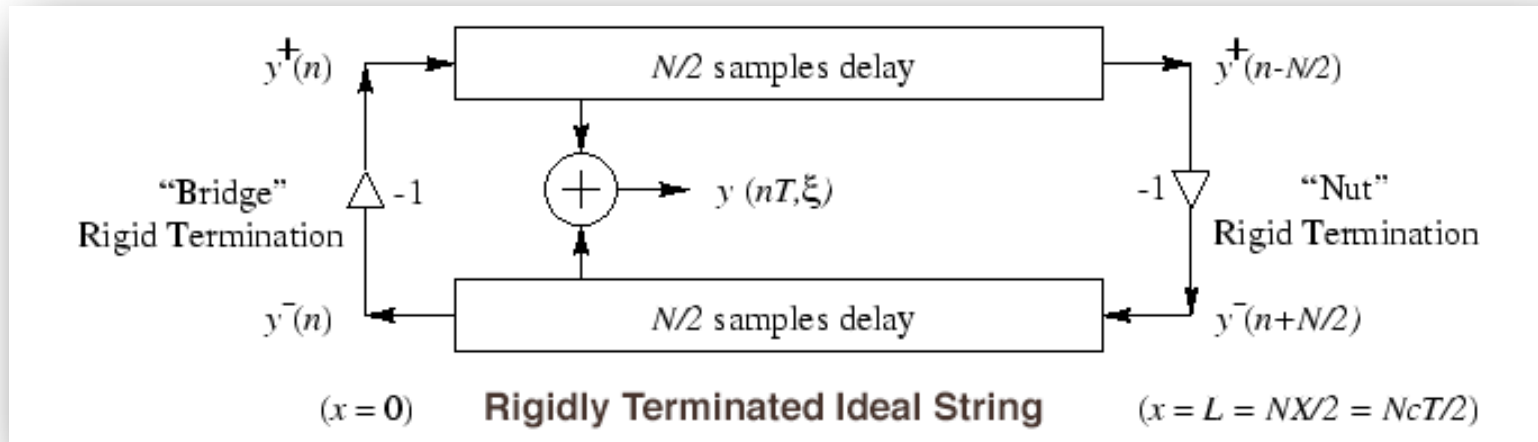

What is Physical Modeling Synthesis?

- Methods in which a sound is generated using a mathematical model of the physical source of sound.
- Any gestures that are used to interact with a real physical system can be mapped to parameters yielded an interactive and expressive performance experience.
- **Physical modeling is a collection of different techniques specific to each sound generation process.**

$$\frac{\partial^2 y}{\partial t^2} = \frac{1}{v_w^2} \frac{\partial^2 y}{dt^2}$$

The GeoShred Model

- A hybrid of Extended Karplus-Strong, Waveguide, Commuted Synthesis with extensions:
 - Harmonics and pinch harmonics
 - Pre-computed pickup excitations
 - Collisions for fret excitation
 - Sitar Bridge model
 - Body Model
 - Hexaphonic split
 - Doubling of courses
 - Statistical variations
- Calibrated from real recordings

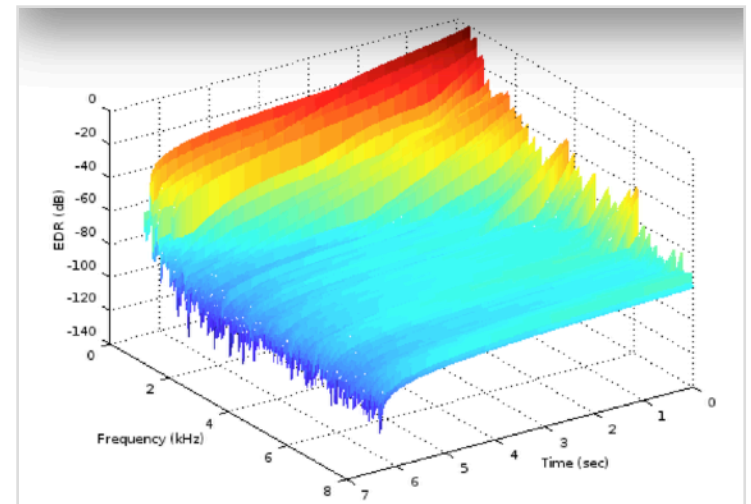
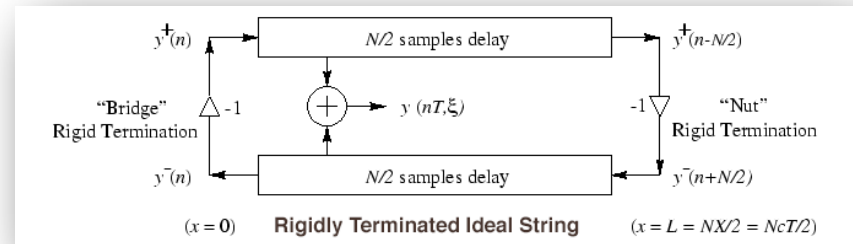

String Model Physical Parameters

- Feedback
- Material
- Fret Scraping
- Harmonics
- String Scraping
- Pick Position
- String Stiffness
- String Doubling
- Sitar Bridge
- Statistical Variations

**Features of the String
Physical Model**



Effects

- 21 Build in effects
- Many are circuit models
- EQs, Distortions, Wah, Moog Filter, Phaser, Flangers, Tremolo, Echos, Reverb
- Any of the 200 parameters in GeoShred can be tied to musically expressive controls including Key[X|Y|Z], Expression [X|Y] and Sliders



And Support for South Asian Music

- Pitch Rounding
Supports Gamakas
- Sitar Model with
Sympathetic
Strings
- Svara Note Names
- 200 Built-in Ragas
- Sympathetic
Resonator and
Tanpura

**GeoShred and
South Asian Music**



Beyond Real

- Any of the 200 parameters in GeoShred can be expressed musically.
- Multiple Parameters can be expressed with a single control.
- Parameters can be manipulated by a lookup table system called “Curves”.
- New sounds can be created that are beyond real.



Pro Features

- MIDI IN/OUT



- MPE (MIDI Poly Phonic Expression) IN/OUT

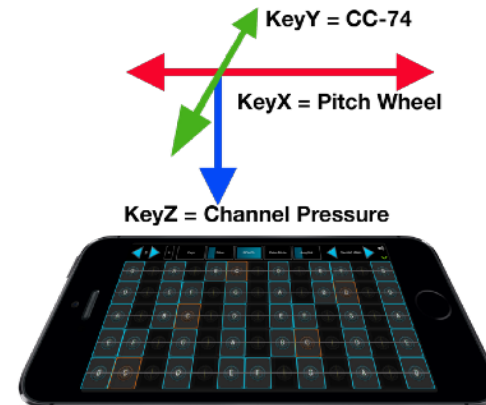

- AudioBus



- InterApp Audio

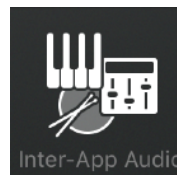

- AUv3 Plugin

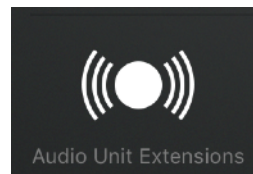

GeoShred's Expressive Control Used with other Synthesizers

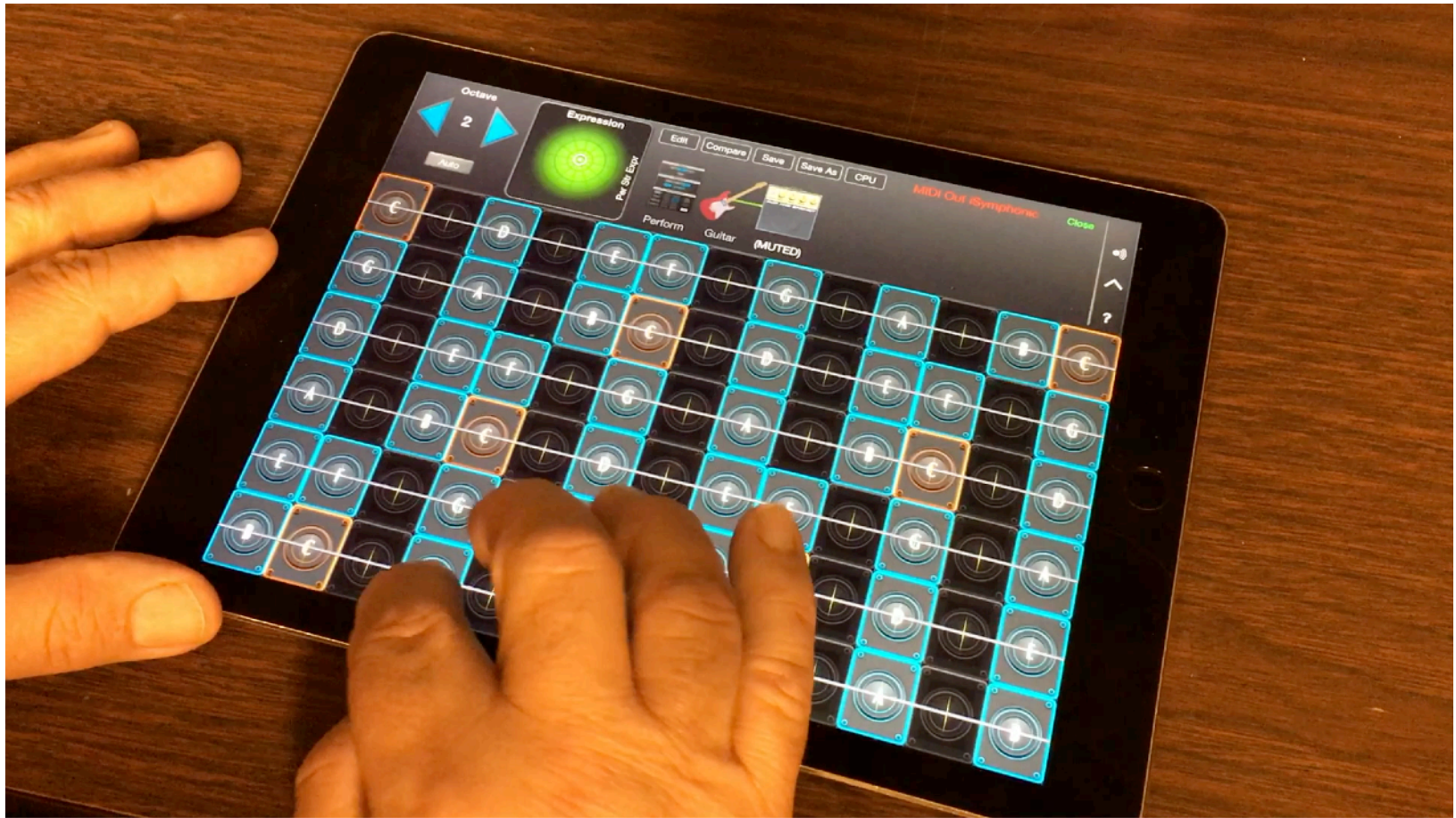

What Comes Next?

- Desktops
- More modeling algorithms from the back room
 - Virtual Analog
 - Percussion
 - Woodwinds
 - FM
 - Other
- Maybe, Alien Orchestras



This Deck and our Full Deck on Physical Modeling Technology:

<http://www.moforte.com> go to the “News and Media” section

Or

This Deck

www.moforte.com/difat

The Full Physical Modeling Deck:

<http://www.moforte.com/berklee-voltage-physical-modeling/>

Quick Demo

Thanks!

- Mary Albertson
- Simone Capitani
- Chris Chafe
- John Chowning
- Perry Cook
- Jon Dattorro
- David Jaffe
- Joe Koepnick
- Romain Michon
- Denis Labrecque
- Scott Levine
- Fernando Lopez-Lezcano
- Yann Orlarey
- Stephane Letz
- Stanford OTL
- Danny Petkevich
- Bill Putnam
- Danielle Rudess
- Kent Sandvik
- Tim Stilson
- David Van Brink
- Scott Van Duyne
- Yamaha



And CCRMA

Questions?

About Pat...

- 36 years in the Silicon Valley as an Engineer
- Built my first monophonic electronic instrument from a Radio Shack kit in 1970.
- Giggged with an Arp Avatar guitar synth (1978)
- Computer Modeling of strings and membranes (1982)
- Researcher in Physical Modeling at Stanford/CCRMA (1994)
- CEO/CTO of moForte

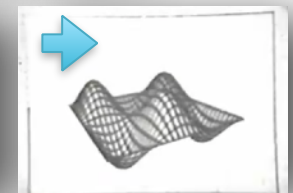
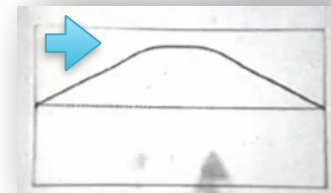

Anticipated Questions

Why Android is a Challenging Platform for Audio Products Targeted for Musicians

- Most Android devices have **audio** latency/jitter issues.
- Roli has measured a Mobile Audio Quality Index MAQi.
- With the exception of a few Android devices, only iOS devices have suitable audio latency/jitter properties
- **moBox is a solution for Android**

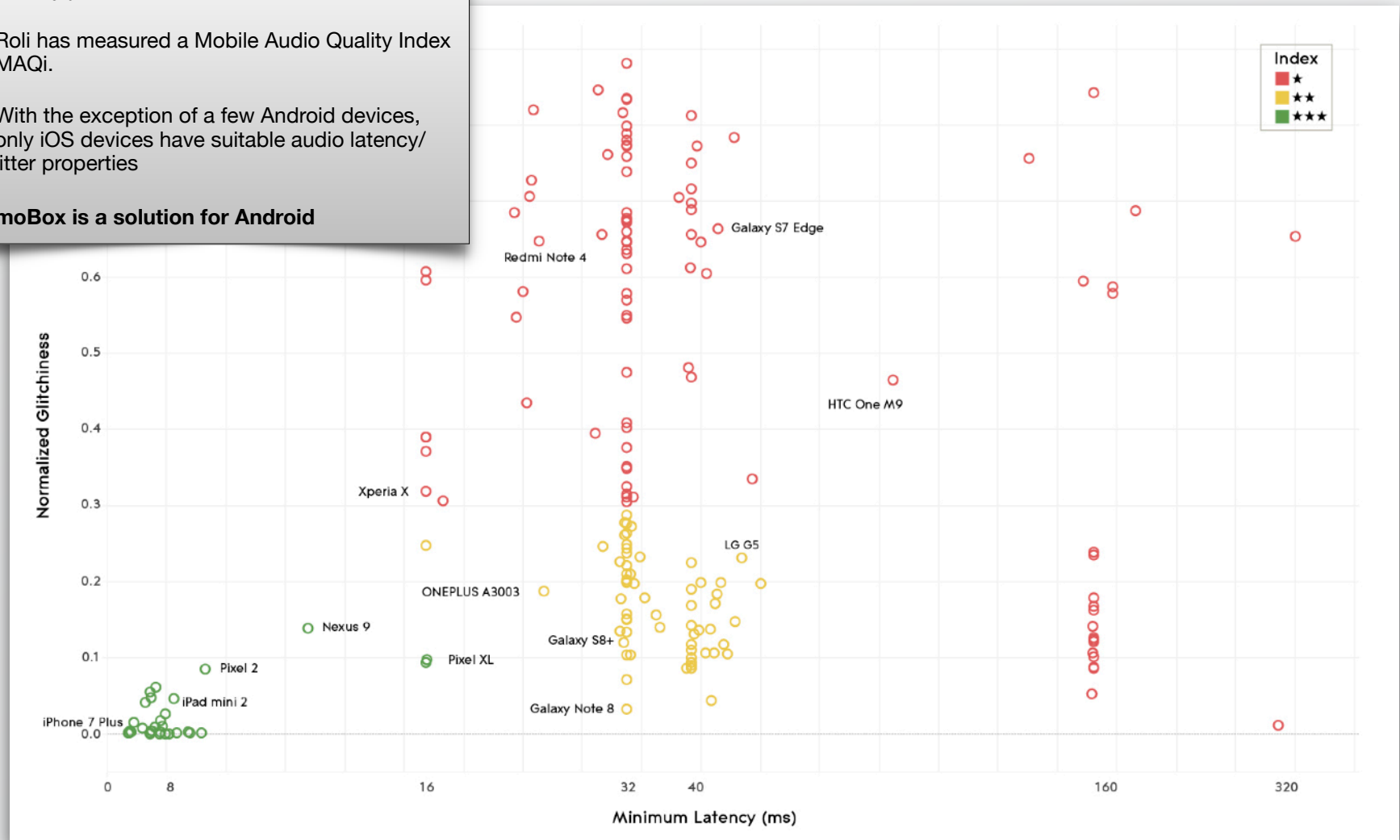

What about Latency?

- The largest source of latency (for ios) appears to be between screen interaction and the guitar model. Note that the audio buffer latency is about 5ms.
- We started at 180ms screen to audio out.
- We brought this down to 25-35ms by replacing Apple's gesture handlers with a custom gesture handler. This makes sense. Gesture handling requires analysis of a moderate amount of state to initiate an action.
- MIDI to Audio Latency is about 20-30ms.
- PowerStomp which is audio-in/effects chain/audio out is around 18ms.
- Latency to the internal speakers on iOS devices seems to have gotten a bit poorer over time. Probably due to DSP processing for the head phone jack.